

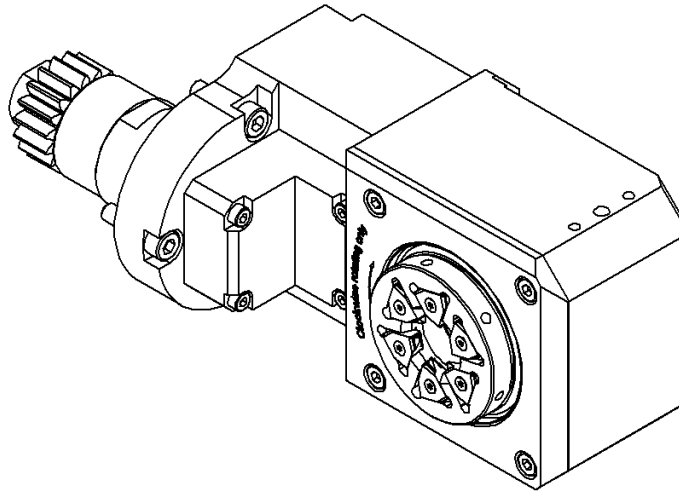



**GSW016**

Machine: CITIZEN Cincom  
Type: D25  
Emplacement, N°: T42 (axe B)  
Travail sur: Broche principale  
Type de travail:   
 $n_{\max}$ : 8'000 [rpm]  
 $i (n_i / n_o)$ : 1 / 1  
Attachement: Changement rapide avec baïonnette  
Sans refroidissement

**Infos:**

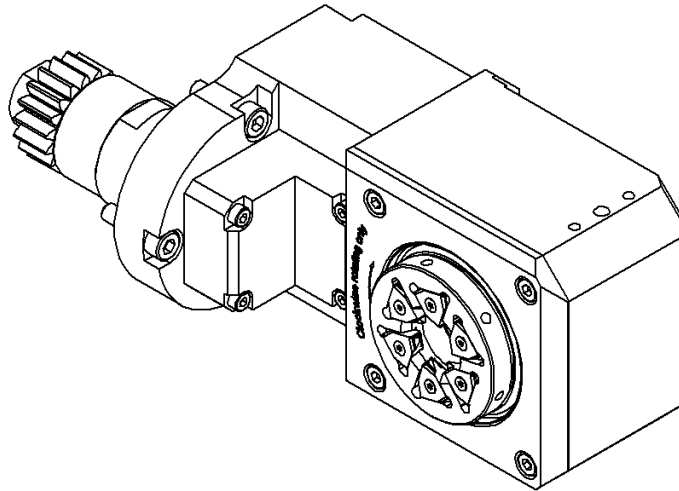
- Inclinaison :  $\pm 16^\circ$
- Têtes compatibles avec fixation rapide : Gloor, Utilise, Schwanog...
- $\varnothing_{\max}$  de passage 12 mm

**GSW016**

Machine: CITIZEN Cincom  
Type: D25  
Location, N°: T42 (axe B)  
Work on: Main spindle  
Type of work:   
 $n_{max}$ : 8'000 [rpm]  
 $i (n_i / n_o)$ : 1 / 1  
Attachement: Quick change with bayonet

Without coolant

**Infos:**

- Inclination :  $\pm 16^\circ$

- Compatible heads with quick attachment : Gloor (round cutters) and Schwanog (triangular cutters)

$\varnothing_{max}$  passing 12mm

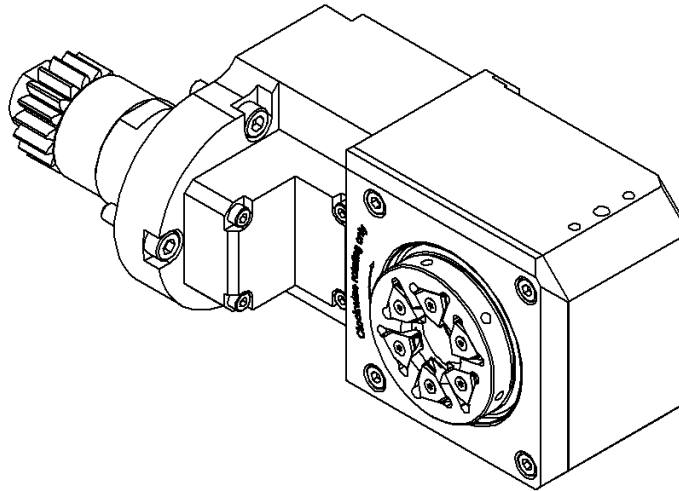
**GSW016**

Maschine: CITIZEN Cincom  
Typ: D25  
Position, N°: T42 (axe B)  
Arbeit über: Hauptspindel  
Arbeitstyp:   
 $n_{\max}$ : 8'000 [rpm]  
 $i$  ( $n_i / n_o$ ): 1 / 1  
Befestigung: Schnellwechsel mit Bajonett

Ohne Kühlmittel

**Infos:**

- Neigungswinkel :  $\pm 16^\circ$
- Kompatible Köpfe mit Schnellverschlüssen : Gloor, Schwanog, Utilise...
- $\varnothing_{\max}$  durchgang 12mm

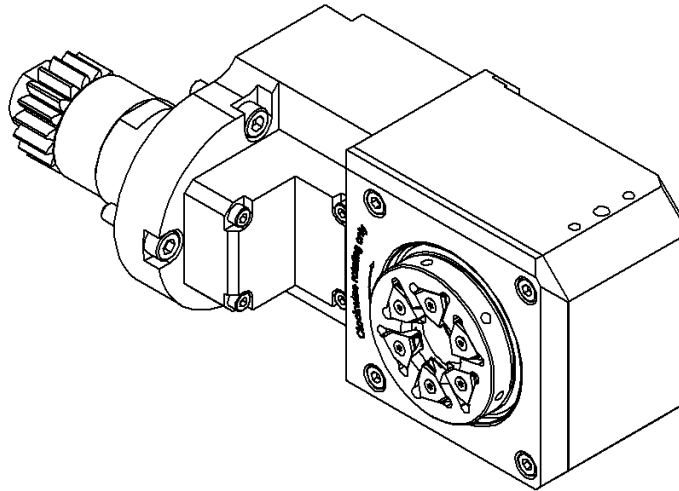
**GSW016**

Macchina: CITIZEN Cincom  
Tipo: D25  
Posizione, N°: T42 (axe B)  
Lavoro al: Mandrino principale  
Tipo di lavoro:   
 $n_{max}$ : 8'000 [rpm]  
 $i (n_i / n_o)$ : 1 / 1  
Ataccamento: Cambio rapido con baionetta

Senza refrigerante

**Informazioni:**

- Inclinazione :  $\pm 16^\circ$
- Teste compatibili con fissaggi a sgancio rapido : Gloor, Schwanog, Utilise...
- $\varnothing_{max}$  di passaggio 12mm