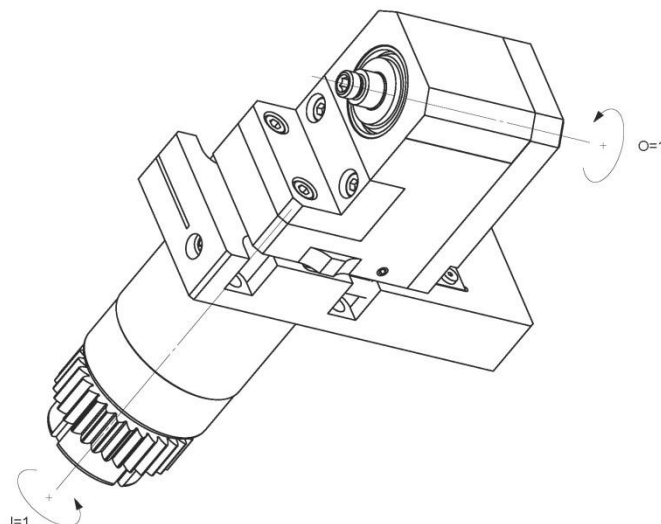

STAR2-GSP-218

Machine: STAR MICRONICS

Type: SB-12/16/20R

Emplacement, N°: Coulisse linéaire / T34-35

Travail sur: Broche principale

Type de travail:  n_{\max} : - [rpm] $i (n_i / n_o)$: 1 / 1

Attachement: Arbre Ø8mm

Sans refroidissement

Infos: Tête de polygonage interchangeable (GSP-218) montée sur queue STAR2-PCR.

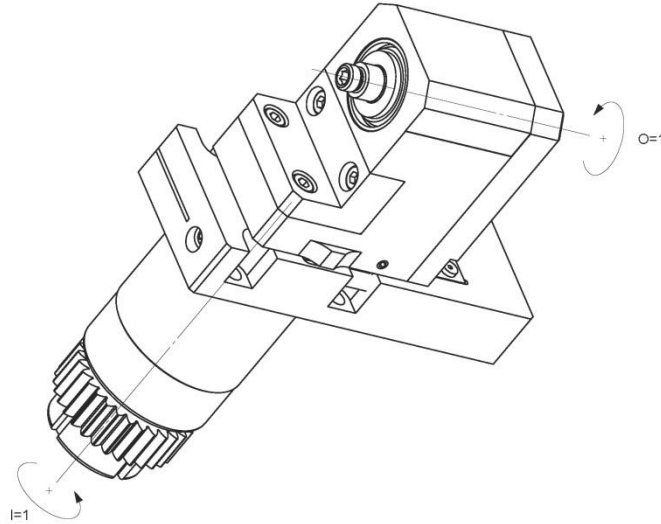
STAR2-GSP-218

Machine: STAR MICRONICS

Type: SB-12/16/20R

Location, N°: Gangtool / T34-35

Work on: Main spindle

Type of work:  n_{\max} : - [rpm] $i (n_i / n_o)$: 1 / 1

Attachement: Shaft Ø8mm

Without coolant

Infos: Interchangeable polygon head (GSP-218) mounted on shank STAR2-PCR.

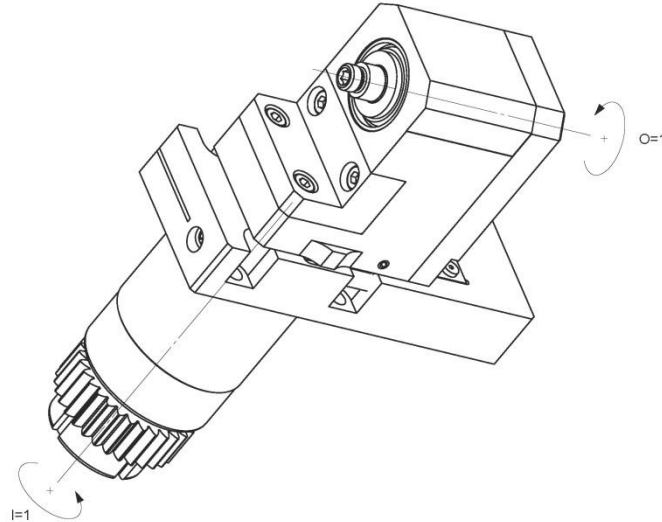
STAR2-GSP-218

Machine: STAR MICRONICS

Typ: SB-12/16/20R

Position, N°: Vertikalhalter / T34-35

Arbeit über: Hauptspindel

Arbeitstyp:  n_{\max} : - [rpm] $i (n_i / n_o)$: 1 / 1

Befestigung: Schaft Ø8mm

Ohne Kühlmittel

Infos: Austauschbar Kopf für Polygonfräserhalter (GSP-218) auf Schaft STAR2-PCR fixiert.

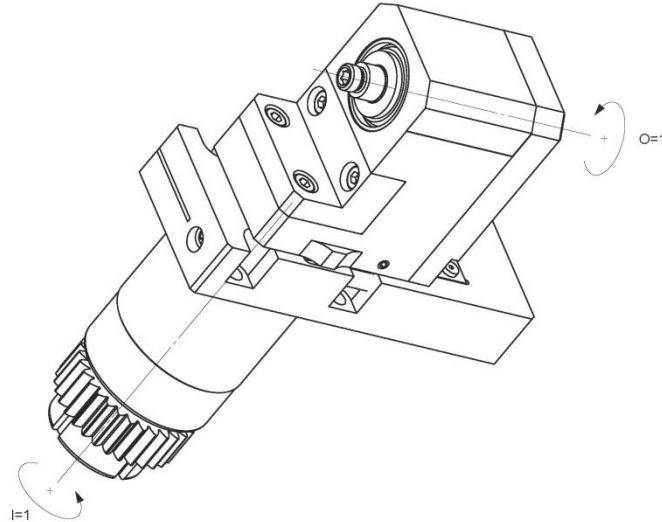
STAR2-GSP-218

Macchina: STAR MICRONICS

Tipo: SB-12/16/20R

Posizione, N°: Slitta lineare / T34-35

Lavoro al: Mandrino principale

Tipo di lavoro:  n_{max} : - [rpm]i (n_i / n_o): 1 / 1

Ataccamento: Codolo Ø8mm

Senza refrigerante

Informazioni: Testa a poligonare intercambiabile (GSP-218) salita sulla coda STAR2-PCR.