

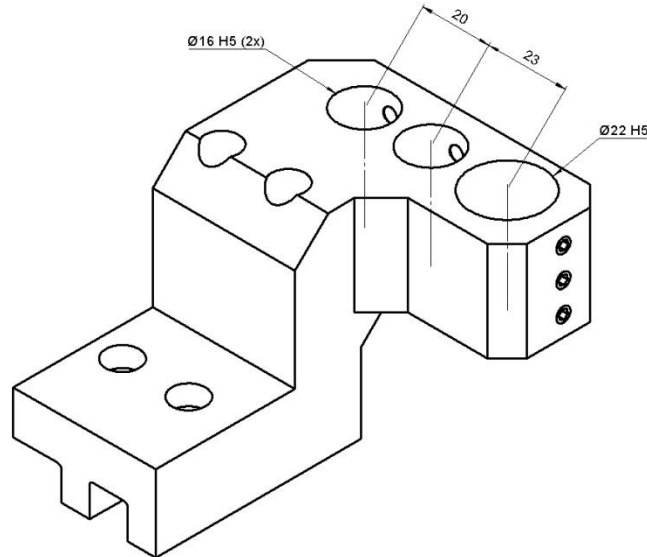

P03-GDF-616

Machine: TSUGAMI

Type: P03

Emplacement, N°: T01 / T02

Travail sur: Broche principale / Broche de reprise

Type de travail:  n_{\max} : - [rpm] i (n_i / n_o): -

Attachement: -

Sans refroidissement

Infos: Porte-barre d'alésage 2xØ16 + 1xØ22

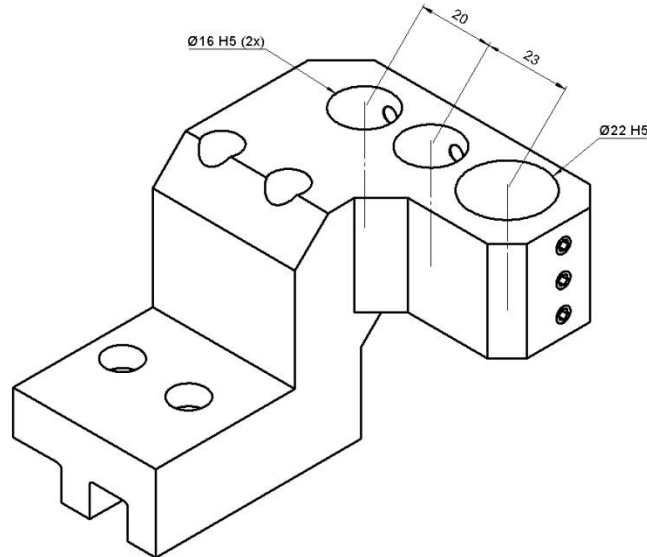
P03-GDF-616

Machine: TSUGAMI
Type: P03
Location, N°: T01 / T02
Work on: Main spindle / Back spindle
Type of work: 
 n_{max} : - [rpm]
 i (n_i / n_o): -
Attachement: -
Without coolant :
Infos: Boring bar holder 2xØ16 + 1xØ22

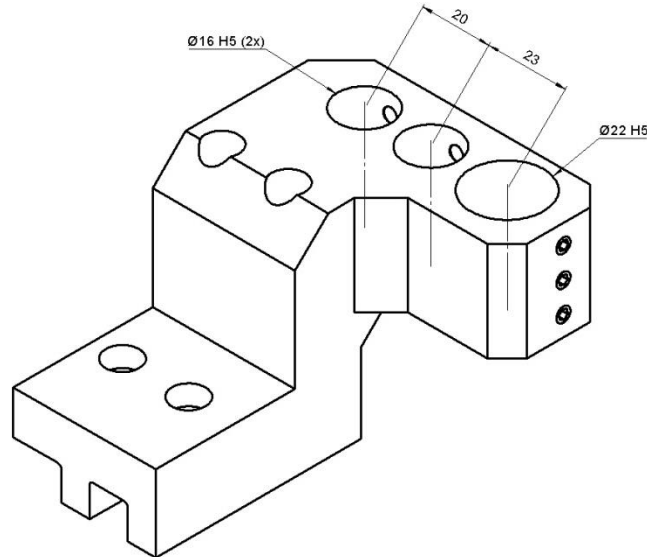
P03-GDF-616

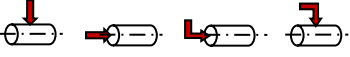
Maschine: TSUGAMI
Typ: P03
Position, N°: T01 / T02
Arbeit über: Hauptspindel / Abgreifspindel
Arbeitstyp: 
 n_{max} : - [rpm]
 $i\ (n_i / n_o)$: -
Befestigung: -
Ohne Kühlmittel:
Infos: Bohrstangenaufnahme 2x $\varnothing 16$ + 1x $\varnothing 22$

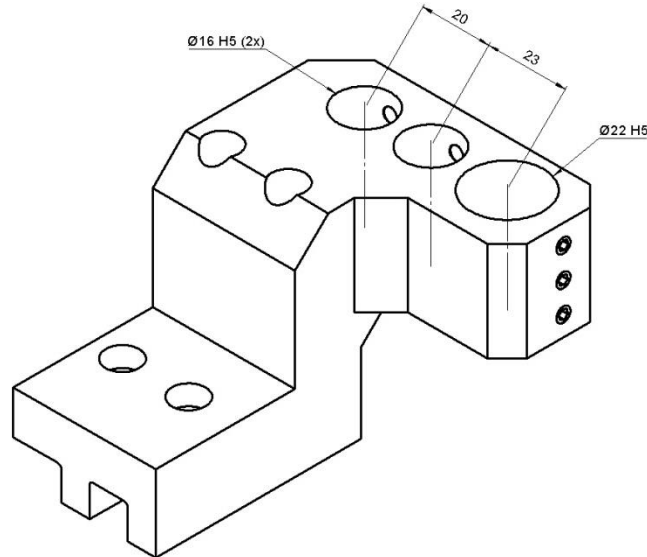
P03-GDF-616

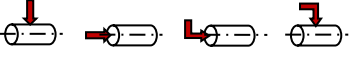
Macchina: TSUGAMI
Tipo: P03
Posizione, N°: T01 / T02
Lavoro al: Mandrino principale / Contromandrino
Tipo di lavoro: 
 n_{max} : - [rpm]
 i (n_i / n_o): -
Ataccamento: -
Senza refrigerante
Informazioni: Porta-barra di alesaggio 2x $\varnothing 16$ + 1x $\varnothing 22$