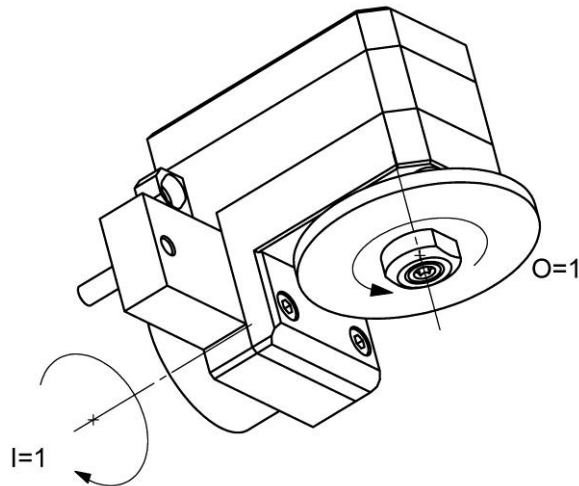

**P03-GSP-218**

Machine: TSUGAMI

Type: P03

Emplacement, N°: Coulisse linéaire

Travail sur: Broche principale

Type de travail:  $n_{\max}$ : 8'000 [rpm] $i$  ( $n_i / n_o$ ): 1 / 1

Attachement: Arbre Ø 8

Sans refroidissement

Infos:

- Polygoneur pour bloc P03-GSC-117-S
- Fraise disque utilisée,  $\varnothing_{\max}=45\text{mm}$ , Largeur=L=3mm
- Ligne de coupe alignée aux burins du bloc P03-GSC-117-S

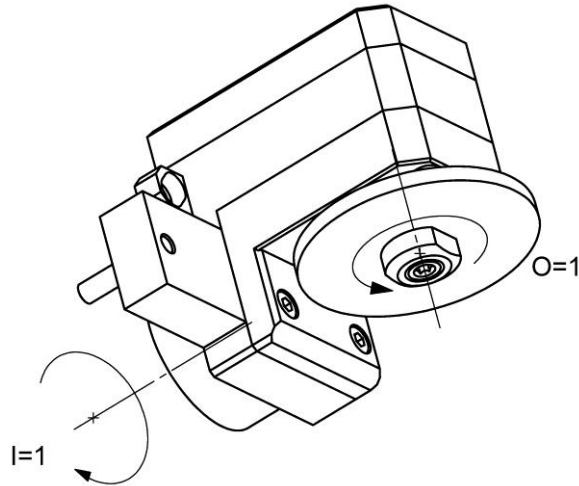
**P03-GSP-218**

Machine: TSUGAMI  
Type: P03  
Location, N°: Gangtool  
Work on: Main spindle  
Type of work:   
 $n_{\max}$ : 8'000 [rpm]  
 $i (n_i / n_o)$ : 1 / 1  
Attachement: Arbor  $\varnothing$  8

Without coolant

**Infos:**

- Driven toolholder for polygon milling on the support P03-GSC-117-S
- Milling cutters,  $\varnothing_{\max}=45\text{mm}$ , Width=L=3mm
- Line of cutting aligned in the chisels of the support P03-GSC-117-S

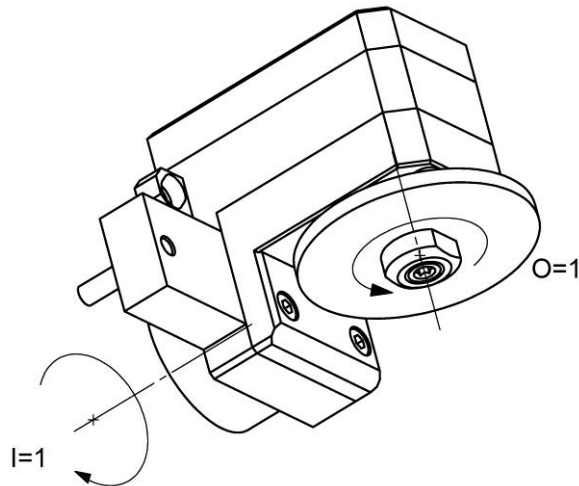
**P03-GSP-218**

Maschine: TSUGAMI  
Typ: P03  
Position, N°: Vertikalhalter  
Arbeit über: Hauptspindel  
Arbeitstyp:   
 $n_{max}$ : 8'000 [rpm]  
 $i$  ( $n_i / n_o$ ): 1 / 1  
Befestigung: Welle Ø 8

Ohne Kühlmittel

Infos:

- Angetriebener Fräserhalter für Polygonfräser für P03-GSC-117-S
- Polygonfräser,  $\varnothing_{max}=45mm$ , Breite=L=3mm
- Schnittlinie zu den p03 Träger Meißel ausgerichtet

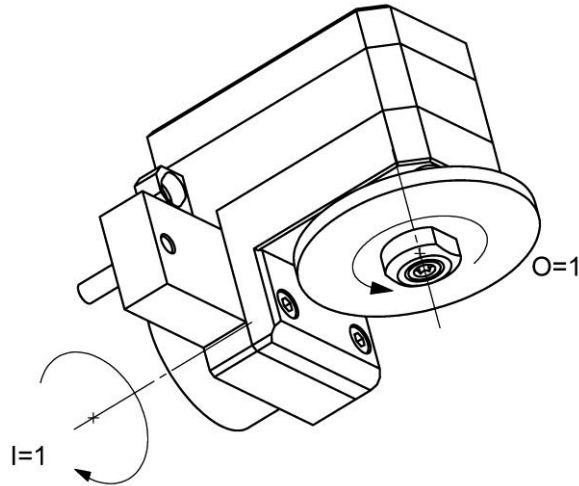
**P03-GSP-218**

Macchina: TSUGAMI  
Tipo: P03  
Posizione, N°: Slitta lineare  
Lavoro al: Mandrino principale  
Tipo di lavoro:   
 $n_{max}$ : 8'000 [rpm]  
 $i$  ( $n_i / n_o$ ): 1 / 1  
Ataccamento: Albero  $\varnothing$  8

Senza refrigerante

**Informazioni:**

- Porta-autensile per poligono fresatura sul supporto P03-GSC-117-S
- Poligono fresatura,  $\varnothing_{max}=45\text{mm}$ , Larghezza=L=3mm
- Linea di taglio allineato ai bulini del supporto P03-GSC-117-S