

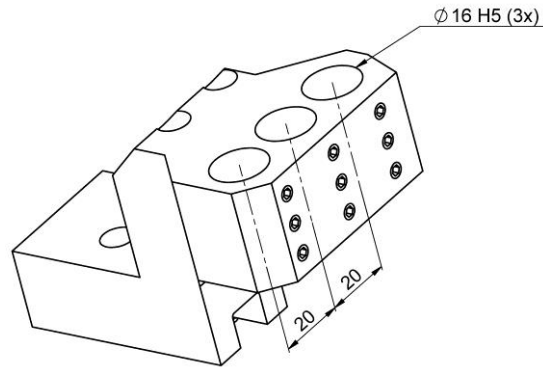

P03-GDF-516

Machine: TSUGAMI

Type: P03

Emplacement, N°: T01+T02 / T13+T14 / T14+T15 / T15+T16 / T16+T17

Travail sur: Broche principale / Broche de reprise

Type de travail:   n_{max} : - [rpm]i (n_i / n_o): 1 / 1

Attachement: Autre

Sans refroidissement Pression maximale: _ [bar]

Infos: Porte-barre d'alésage 3xØ16

P03-GDF-516

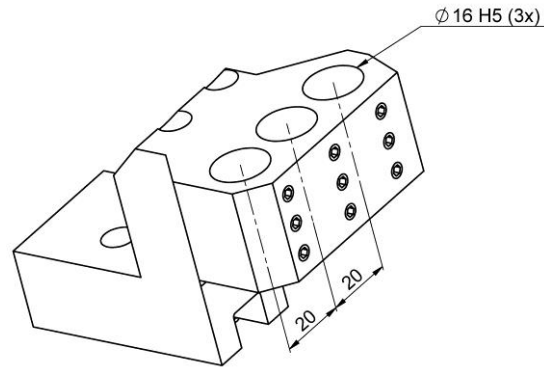

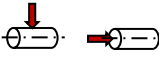

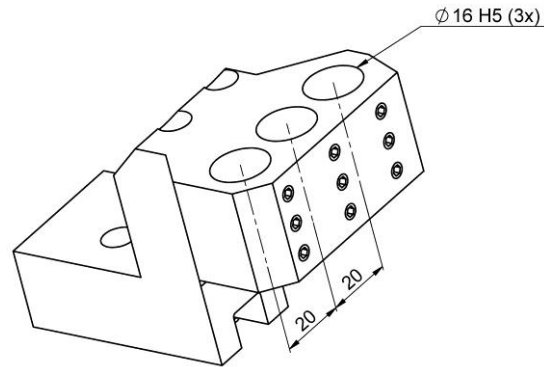
Machine: TSUGAMI
 Type: P03
 Location, N°: T01+T02 / T13+T14 / T14+T15 / T15+T16 / T16+T17
 Work on: Main spindle / Back spindle
 Type of work: 
 n_{max}: - [rpm]
 i (n_i / n_o): 1 / 1
 Attachement: Other
 Without coolan Maximum pressure: _ [bar]
 Infos: Boring bar holder 3xØ16

P03-GDF-516

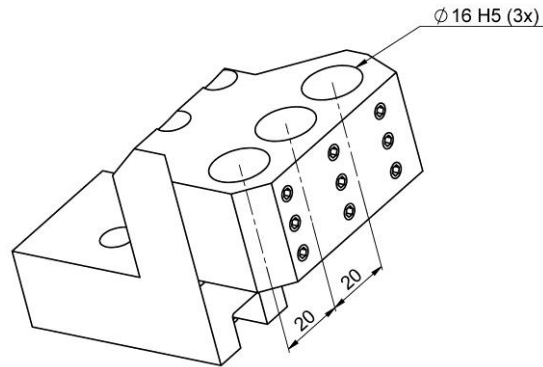
Maschine: TSUGAMI
Typ: P03
Position, N°: T01+T02 / T13+T14 / T14+T15 / T15+T16 / T16+T17
Arbeit über: Hauptspindel / Abgreifspindel
Arbeitstyp: 
 n_{\max} : - [rpm]
 $i (n_i / n_o)$: 1 / 1
Befestigung: Andere
Ohne Kühlmittel Drück: _ [bar]
Infos: Bohrstangenaufnahme 3xØ16

P03-GDF-516

Macchina: TSUGAMI
Tipo: P03
Posizione, N°: T01+T02 / T13+T14 / T14+T15 / T15+T16 / T16+T17
Lavoro al: Mandrino principale / Contromandrino
Tipo di lavoro:  
 n_{max} : - [rpm]
 $i (n_i / n_o)$: 1 / 1
Ataccamento: Altro
Senza refrigerante Pressione massima: _ [bar]
Informazioni: Porta-barra di alesaggio 3xØ16