

M32-5M5: Stroke Y2 :70
M32-4M5: Stroke Y2 : 48

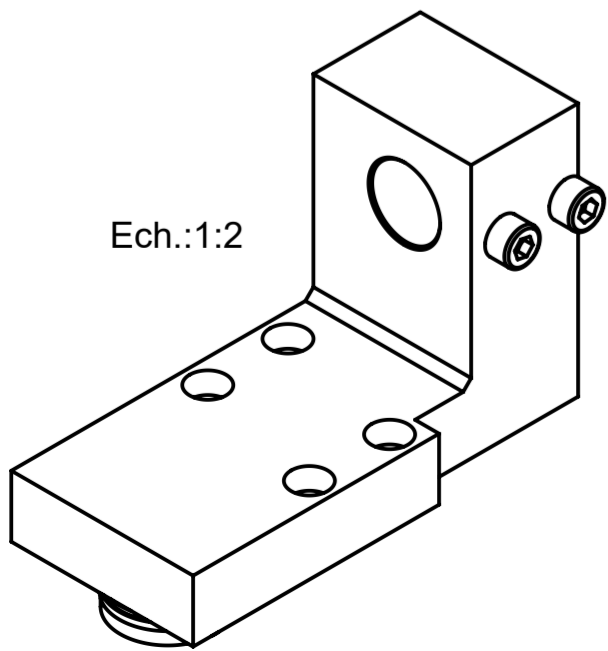
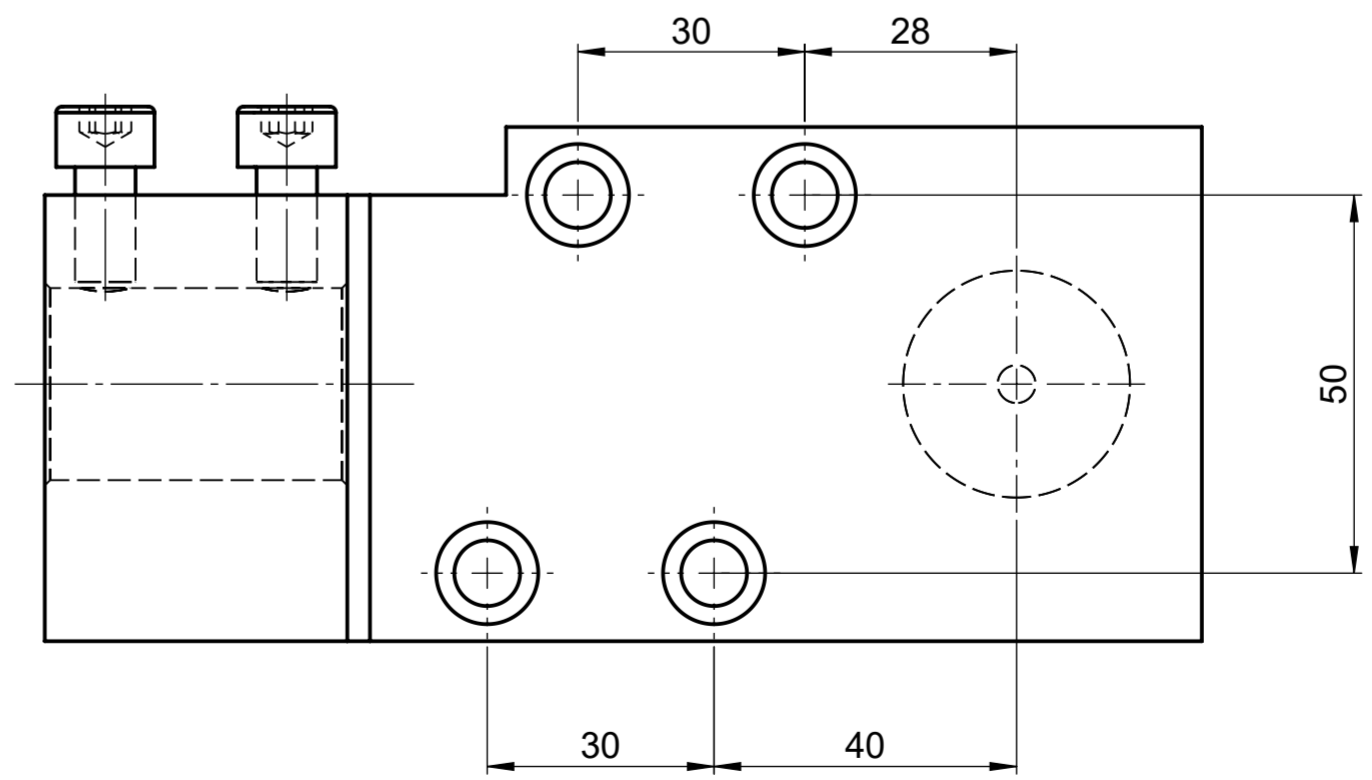
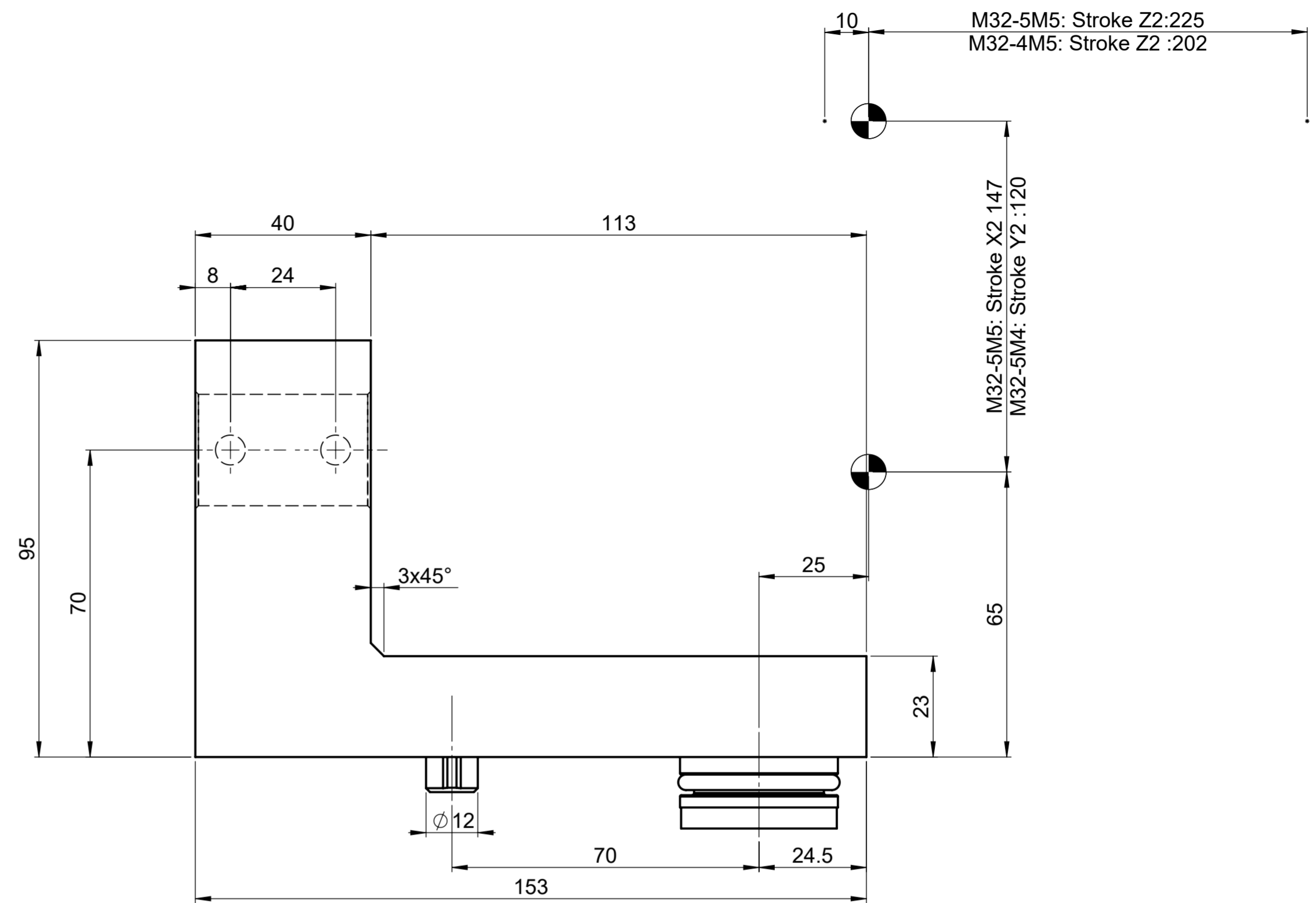
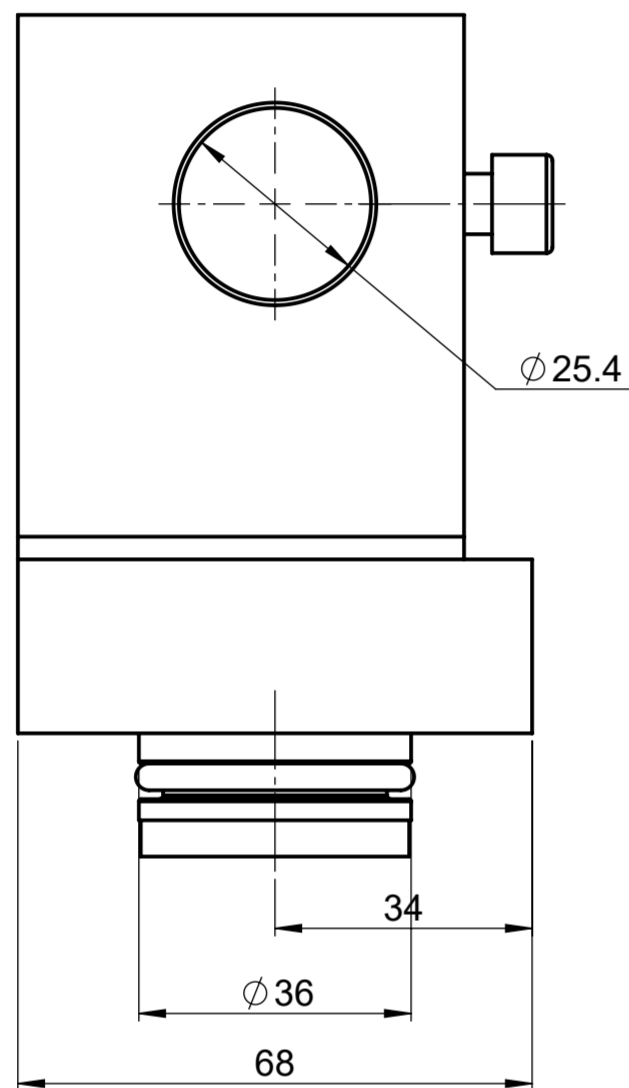

Ech.:1:2

BORING BAR HOLDER
POSITION : Turret
SHANK Ø : Ø 25.4mm (standard)
COOLANT : No
MACHINE TYPES :CITIZEN M20-2M3/5,
M20-3M3/5,M32-2M3/5,M32-3M3/5,M32-
4M3/5/7/8,M32-5M5/7/8

Porte-barre d'alésage Ø25.4	<small>The reproduction, distribution and utilization of this document as well as the communication of its contents to others without express authorization is prohibited. Offenders will be held liable for the payment of damages. All rights reserved in the event of the grant of a patent, utility model or design.</small>		Créé	Moll	03.05.10
			Validé	Pilet	20.02.2026
CDF101-SP	Révision A	 PCM be driven.	<small>PCM Precision Tooling SA +41 21 967 33 66 CH-1844 Villeneuve www.pcm.ch</small>		