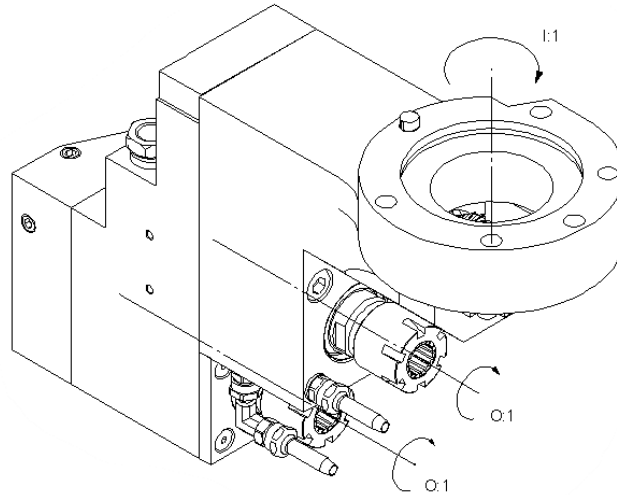

MEU210-IK

Machine: Citizen

Type: M16-4M8

Emplacement, N°: Upper gang tool post

Travail sur: Broche principale

Type de travail: i (n_i / n_o): 1 / 1

Attachement: ER 16

Refroidissement externe Pression maximale: 200 [bar]

Infos:

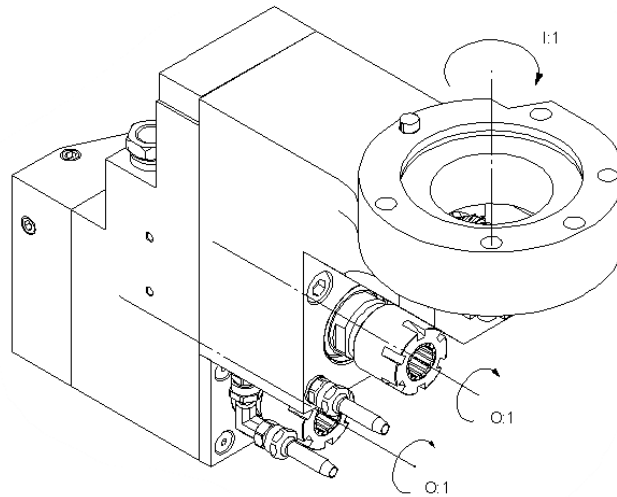
MEU210-IK

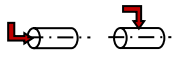
Machine: Citizen
Type: M16-4M8
Location, N°: Upper gang tool post
Work on: Main spindle
Type of work: 
i (n_i / n₀): 1 / 1
Attachement: ER 16
External coolant Maximum pressure: 200 [bar]
Infos:

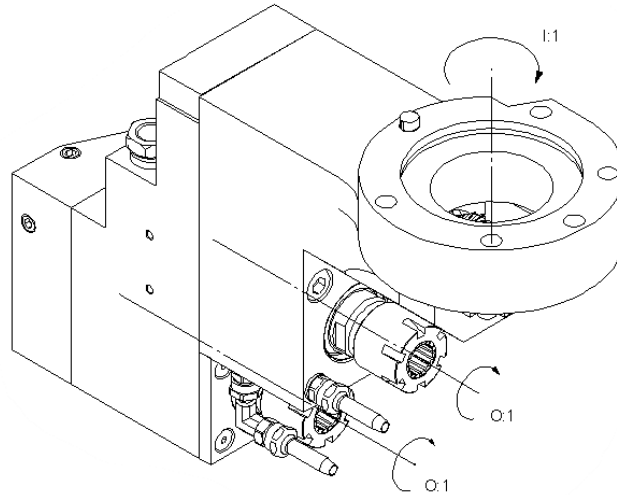
MEU210-IK

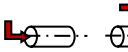
Maschine: Citizen
Typ: M16-4M8
Position, N°: Upper gang tool post
Arbeit über: Hauptspindel
Arbeitstyp: 
i (n_i / n₀): 1 / 1
Befestigung: ER 16

Ausser Kühlmittel Maximaler Drück: 200 [bar]

Infos: