

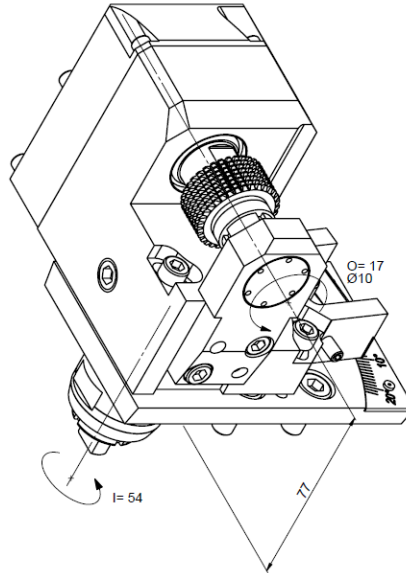

**KSH332**

Machine: CITIZEN  
Type: M532  
Emplacement, N°: Turret  
Travail sur: Broche principale  
Type de travail:   
i (n<sub>i</sub> / n<sub>o</sub>): 54 / 17  
Attachement: Arbre Ø 10

Sans refroidissement

Infos:

Diamètre de la fraise : Ø 32mm

Epaisseur de la fraise : 20-30mm

**KSH332**

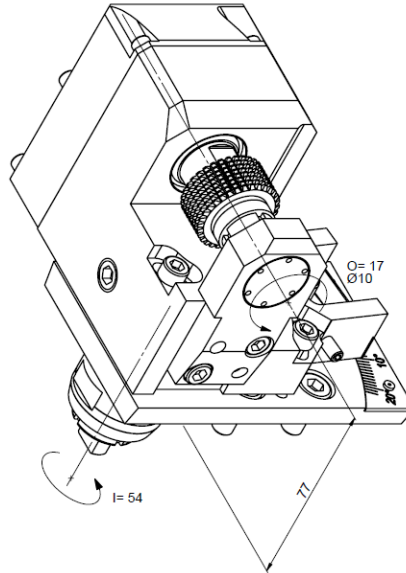

Machine: CITIZEN  
Type: M532  
Location, N°: Turret  
Work on: Main spindle  
Type of work:   
i (n<sub>i</sub> / n<sub>o</sub>): 54 / 17  
Attachement: Arbor Ø 10  
Without coolant  
Infos:  
Diameter of the mill : Ø 32mm  
Width of mill cutter : 20-30mm

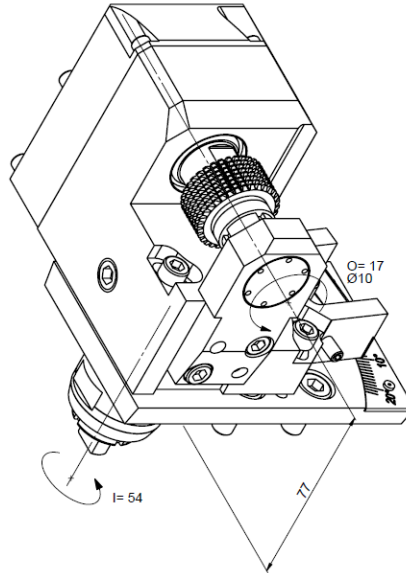
**KSH332**

Maschine: CITIZEN  
Typ: M532  
Position, N°: Turret  
Arbeit über: Hauptspindel  
Arbeitstyp:   
i (n<sub>i</sub> / n<sub>o</sub>): 54 / 17  
Befestigung: Welle Ø 10

Ohne Kühlmittel

Infos:

Fräserdurchmesser : Ø 32mm

Breite des Fräasers : 20-30mm