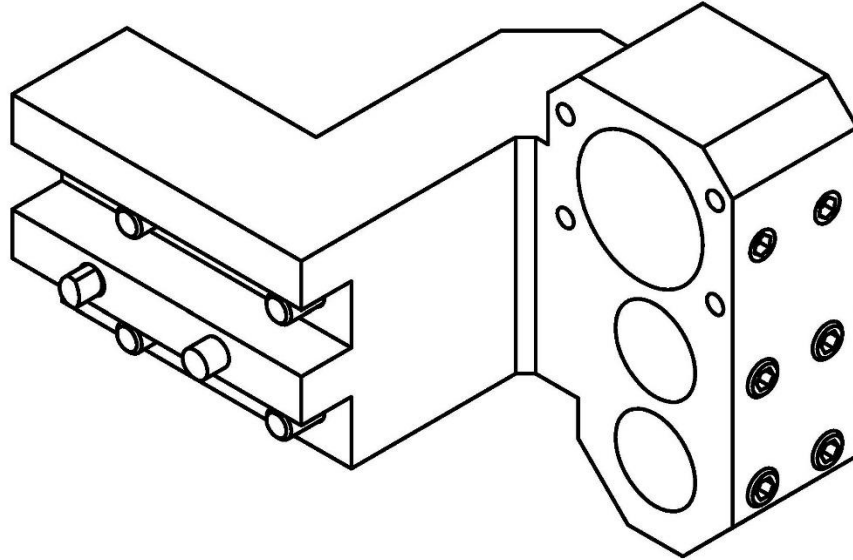

**P03-GDF-816-II**

Machine: TSUGAMI

Type: P013/P014/P033/P034

Emplacement, N°: Back gang tool post

Travail sur: Broche principale / Broche de reprise

Type de travail: i (n<sub>i</sub> / n<sub>o</sub>): - / -

Attachement:

Sans refroidissement

Infos:

- Porte-barre d'alésage
- 2xØ16 et 1xØ25

**P03-GDF-816-II**

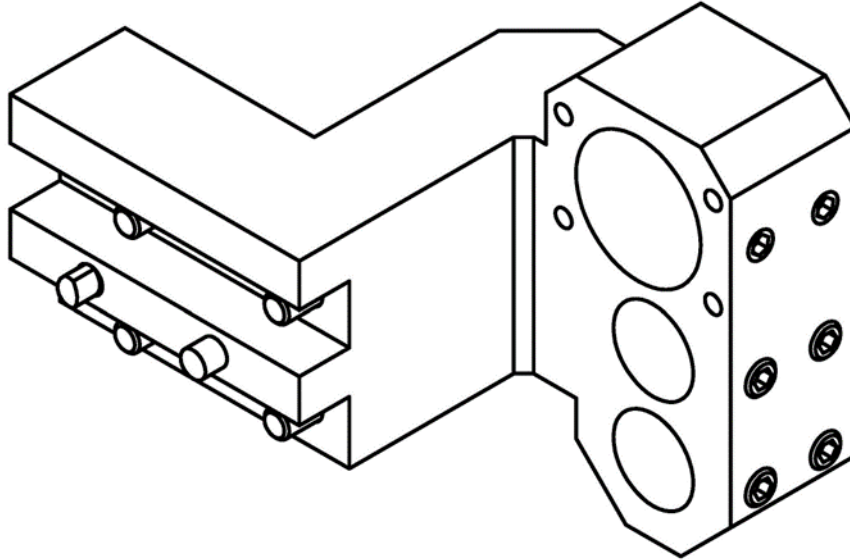

Machine: TSUGAMI  
Type: P013/P014/P033/P034  
Location, N°: Back gang tool post  
Work on: Main spindle / Back spindle

Type of work: 

i (n<sub>i</sub> / n<sub>o</sub>): - /

Attachement:

Without cooling

Infos:

- Boring bar holder
- 2xØ16 and 1xØ25

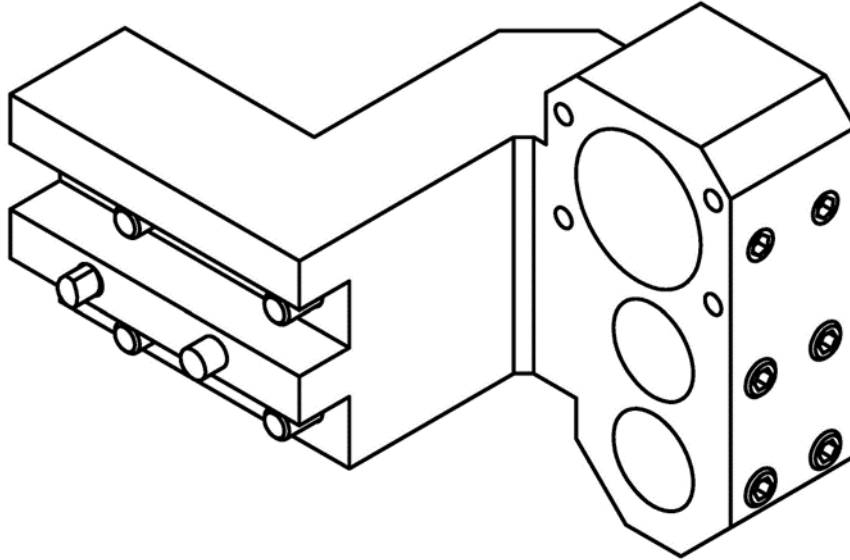
**P03-GDF-816-II**

Maschine: TSUGAMI  
Typ: P013/P014/P033/P034  
Position, N°: Back gang tool post  
Arbeit über: Hauptspindel / Abgreifspindel  
Arbeitstyp:   
i (n<sub>i</sub> / n<sub>o</sub>): - /

Befestigung:

Ohne Kühlmittel

Infos:

- Bohrstangenaufnahme
- 2xØ16 und 1xØ25