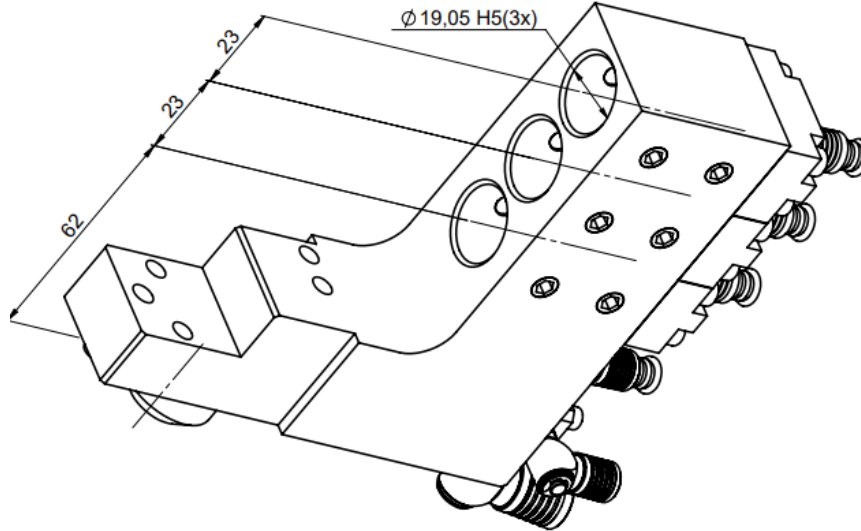

GDF1302-IK

Machine: CITIZEN

Type: L12-2M10

Emplacement, N° : GSE4107, T12-T13

Travail sur : Broche principale

Type de travail:  n_{\max} :i (n_i / n_o):Attachement: 3x $\varnothing 19,05 \text{ mm}$

Refroidissement interne Pression maximale: 220 [bar]

Infos:

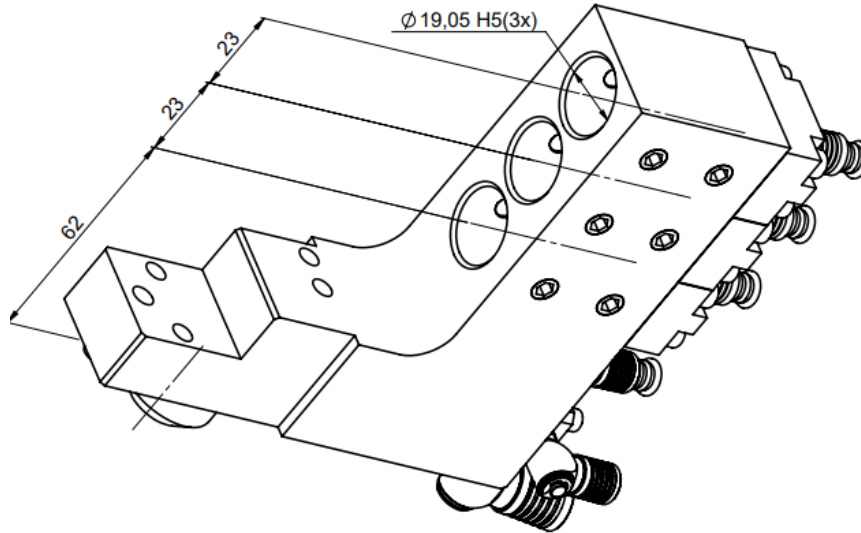
GDF1302-IK

Machine: CITIZEN
Type: L12-2M10
Location, N° : GSE4107, T12-T13
Work on: Main spindle
Type of work: 
 n_{max} :
 $i (n_i / n_o)$:
Attachement: 3x $\varnothing 19.05$ mm
Internal coolant Maximum pressure: 220 [bar]
Infos:

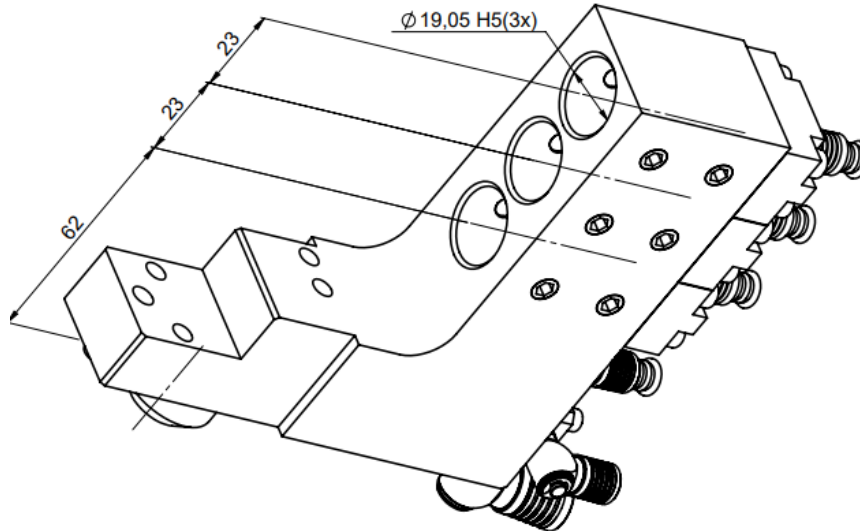
GDF1302-IK

Maschine: CITIZEN
Typ: L12-2M10
Position, N° : GSE4107, T12-T13
Arbeit über: Hauptspindel
Arbeitstyp: 
 n_{max} :
 i (n_i / n_o):
Befestigung: 3x $\varnothing 19.05$ mm
Inner Kühlmittel Maximaler Druck: 220 [bar]
Infos: