

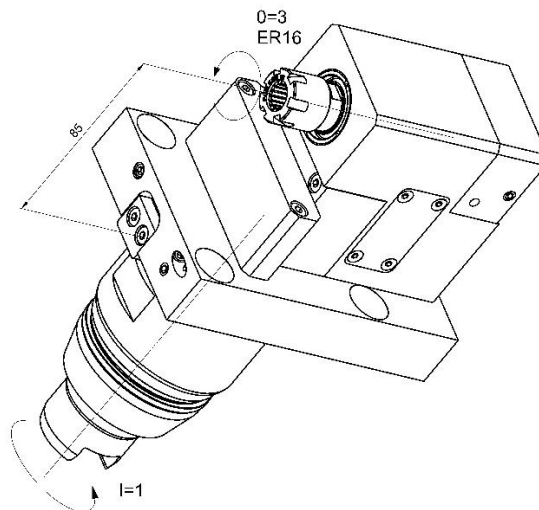

0400-SC016-R00AH0-1S01

Machine: TSUGAMI

Type: M08SY-2

Emplacement, N°: Turret

Travail sur: Broche de reprise

Type de travail: i (n_i / n_o): 1 / 3

Attachement: ER 16

Refroidissement interne Pression maximale: 120 [bar]

Infos: Une huile filtrée à 50µm est nécessaire.

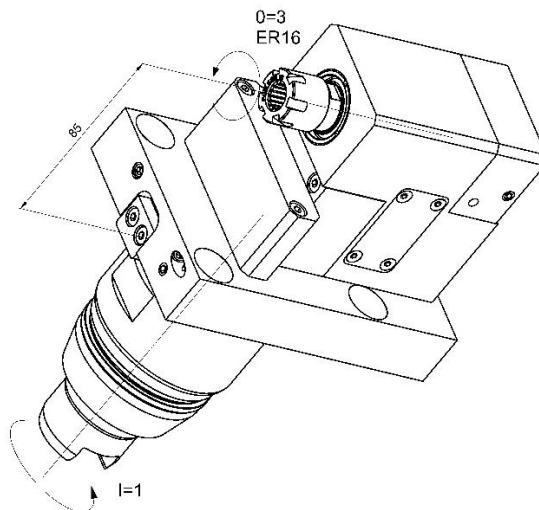
0400-SC016-R00AH0-1S01

Machine: TSUGAMI

Type: M08SY-2

Location, N°: Turret

Work on: Back spindle

Type of work:

i (n_i / n_o): 1 / 3

Attachement: ER 16

Internal coolant Maximum pressure: 120 [bar]

Infos: There is a need for an oil filtered at 50µm.

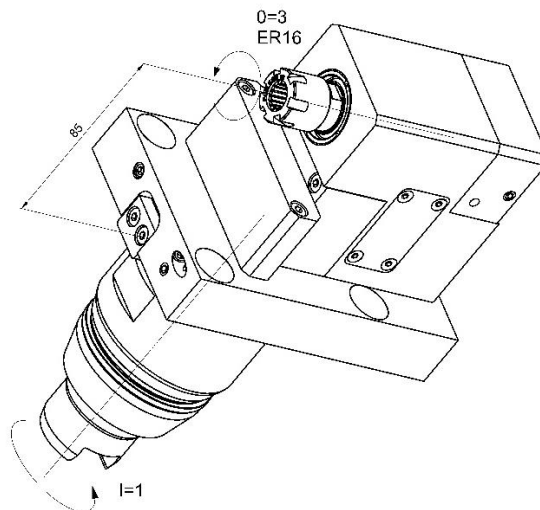
0400-SC016-R00AH0-1S01

Machine: TSUGAMI

Typ: M08SY-2

Position, N°: Turret

Arbeit über: bgreifspindel

Arbeitstyp: i (n_i / n_o): 1 / 3

Befestigung: ER 16

Inner Kühlmittel Maximaler Drück: 120 [bar]

Infos: Es besteht Bedarf an einem auf 50µm gefilterten Öl.