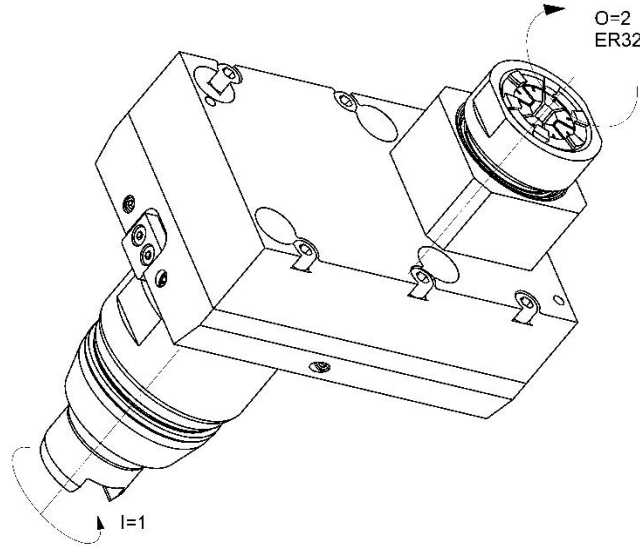

**0400-SC032-A0DAH0-1S01**

Machine: TSUGAMI

Type: M08SY-2

Emplacement, N°: Turret

Travail sur: Broche principale

Type de travail: i (n<sub>i</sub> / n<sub>o</sub>): 1 / 2

Attachement: ER 32

Refroidissement interne Pression maximale: 120 [bar]

Infos: Une huile filtrée à 50µm est nécessaire

**0400-SC032-A0DAH0-1S01**

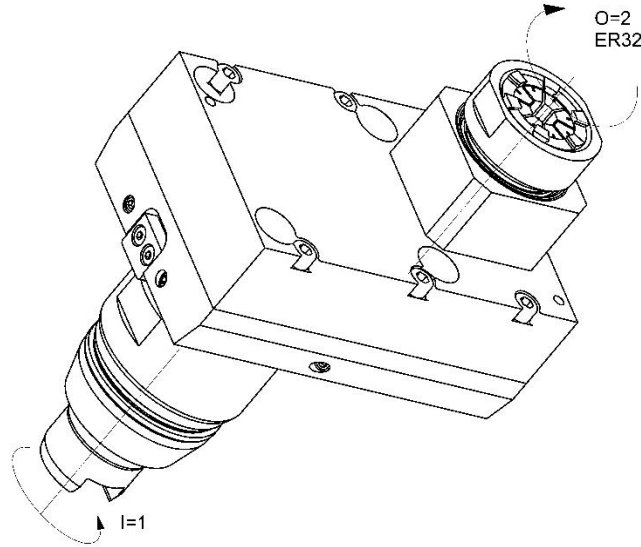

Machine: TSUGAMI

Type: M08SY-2

Location, N°: Turret

Work on: Main spindle

Type of work:

i (n<sub>i</sub> / n<sub>o</sub>): 1 / 2

Attachement: ER 32

Internal coolant Maximum pressure: 120 [bar]

Infos: There is a need for an oil filtered at 50µm.

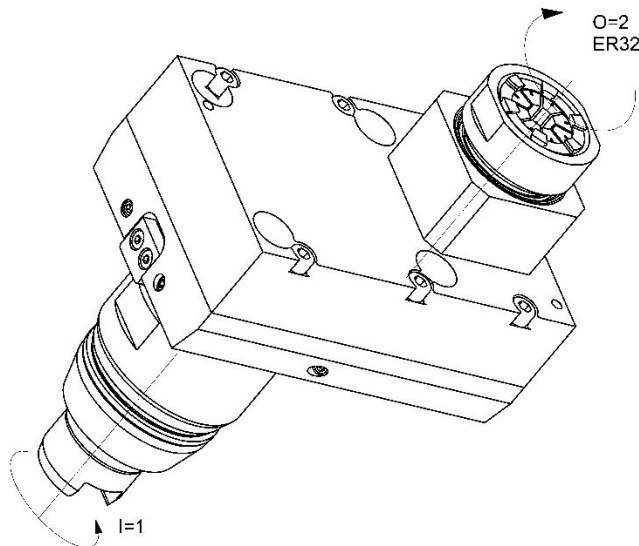
**0400-SC032-A0DAH0-1S01**

Machine: TSUGAMI

Typ: M08SY-2

Position, N°: Turret

Arbeit über: Hauptspindel

Arbeitstyp:

i (n<sub>i</sub> / n<sub>o</sub>): 1 / 2

Befestigung: ER 32

Inner Kühlmittel Maximaler Drück: 120 [bar]

Infos: Es besteht Bedarf an einem auf 50µm gefilterten Öl.