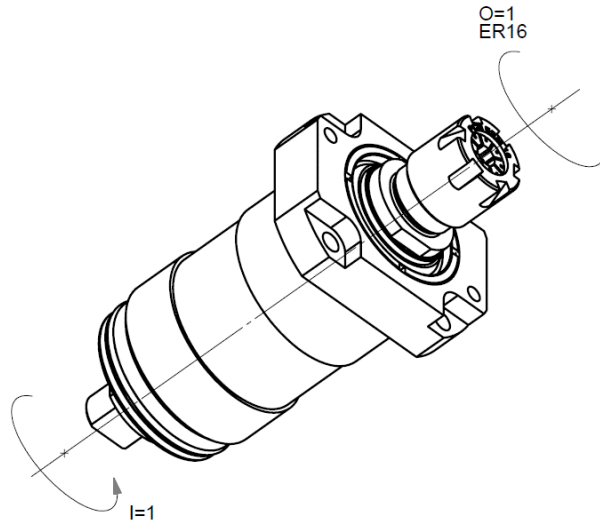

0400-SC016-A00000-1S05

Machine: TSUGAMI

Type: BO265-II/BO266-II/BO325-II/BO326-II/BO385/BO385L

Emplacement, N°: Back gang tool post

Travail sur: Broche principale

Type de travail: i (n_i / n_o): 1 / 1

Attachement: ER16

Sans refroidissement

Infos:

0400-SC016-A00000-1S05

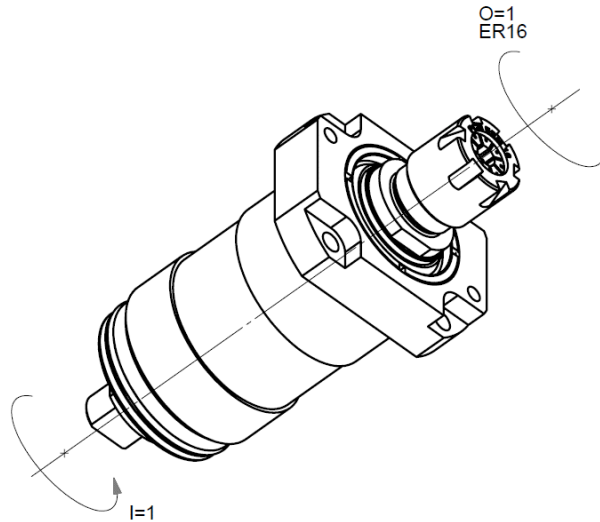

Machine: TSUGAMI
Type: BO265-II/BO266-II/BO325-II/BO326-II/BO385/BO385L
Location, N°: Back gang tool post
Work on: Main spindle
Type of work: 
i (n_i / n_o): 1 / 1
Attachement: ER16
Without coolant
Infos:

0400-SC016-A00000-1S05

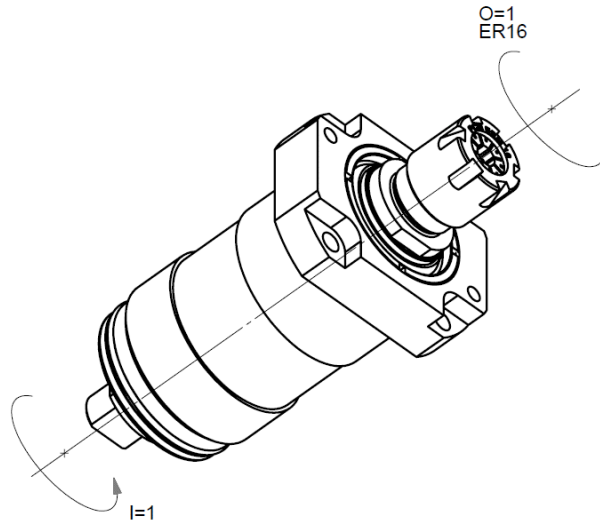

Maschine: TSUGAMI
Typ: BO265-II/BO266-II/BO325-II/BO326-II/BO385/BO385L
Position, N°: Back gang tool post
Arbeit über: Hauptspindel
Arbeitstyp: 
i (n_i / n_o): 1 / 1
Befestigung: ER16
Ohne Kühlmittel
Infos: