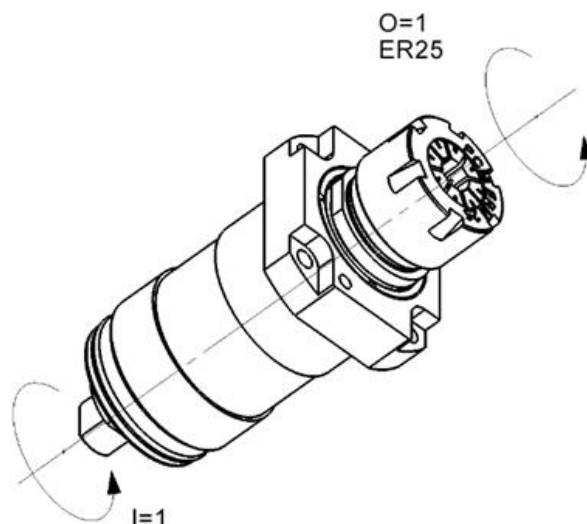

**0400-SC025-A00000-1S02**

Machine: TSUGAMI

Type: BO265-II/BO266-II/BO325-II/BO326-II/BO385/BO385L

Emplacement, N°: Back gang tool post

Travail sur: Broche principale

Type de travail:

i (n<sub>i</sub> / n<sub>o</sub>): 1 / 1

Attachement: ER 25

Sans refroidissement

Infos:

**0400-SC025-A00000-1S02**

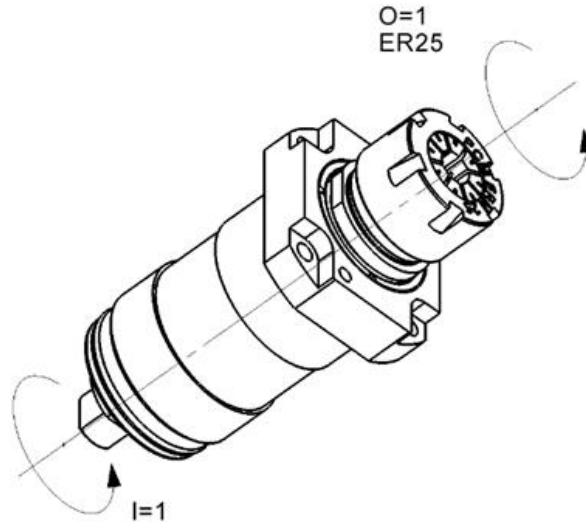

Machine: TSUGAMI  
Type: BO265-II/BO266-II/BO325-II/BO326-II/BO385/BO385L  
Location, N°: Back gang tool post  
Work on: Main spindle  
Type of work:   
i (n<sub>i</sub> / n<sub>o</sub>): 1 / 1  
Attachement: ER25  
Without coolant  
Infos:

**0400-SC025-A00000-1S02**

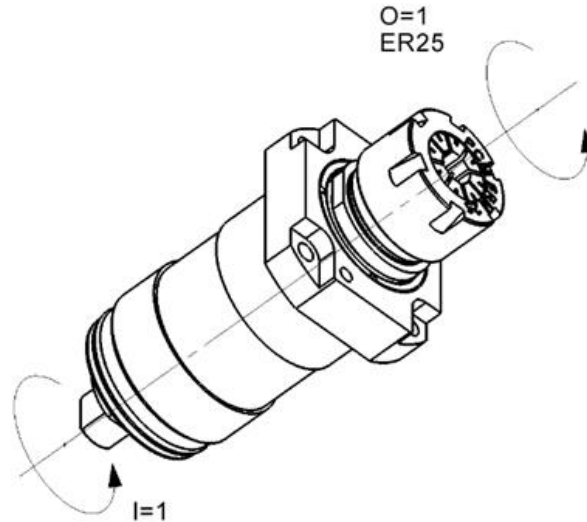

Maschine: TSUGAMI  
Typ: BO265-II/BO266-II/BO325-II/BO326-II/BO385/BO385L  
Position, N°: Back gang tool post  
Arbeit über: Hauptspindel  
Arbeitstyp:   
i (n<sub>i</sub> / n<sub>o</sub>): 1 / 1  
Befestigung: ER25

Ohne Kühlmittel

Infos: