

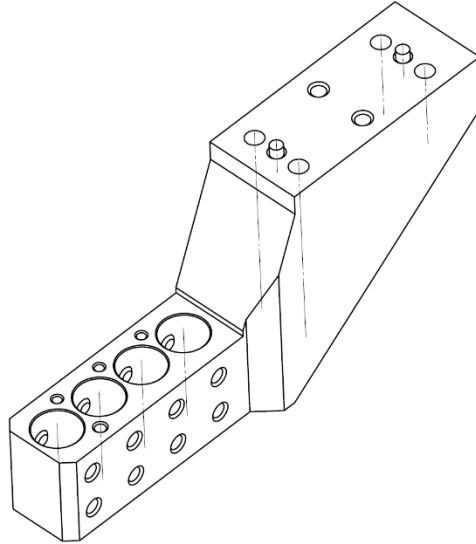



GDF7001-22

Machine: CITIZEN
Type: L12-1M7
Emplacement, N°: Upper gang tool post
Travail sur: Broche principale
Type de travail: 
Attachement: 4x Ø22
Sans refroidissement
Infos: Pour broche HF Ø22

GDF7001-22

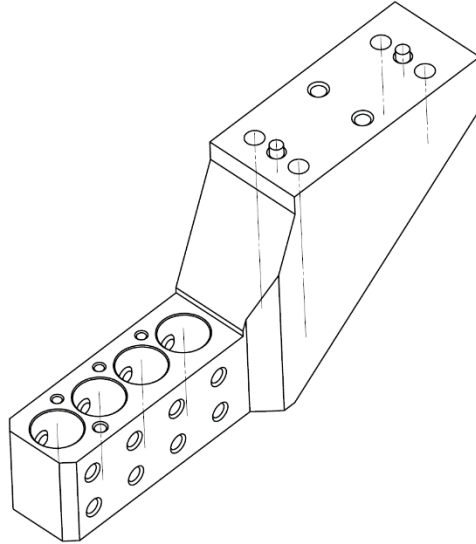

Machine: CITIZEN
Type: L12-1M7
Location, N°: Upper gang tool post
Work on: Main spindle
Type of work: 
Attachement: 4x Ø22
Without coolant
Infos: For HF spindle Ø22

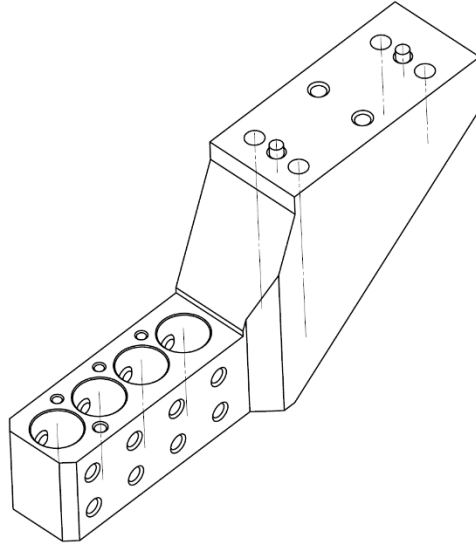
GDF7001-22

Maschine: CITIZEN
Typ: L12-1M7
Position, N°: Upper gang tool post
Arbeit über: Hauptspindel
Arbeitstyp: 
Befestigung: 4x Ø22
Ohne Kühlmittel
Infos: Für HF-Spindel Ø22