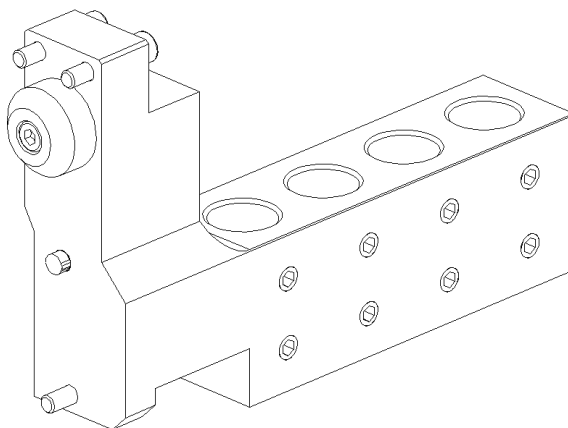

GDF1304

Machine: CITIZEN

Type: L212

Emplacement, N°: T9-T10

Travail sur: Broche principale

Type de travail: i (n_i / n_o):

Attachement: 4x Ø19.05 mm

Sans refroidissement

Infos:

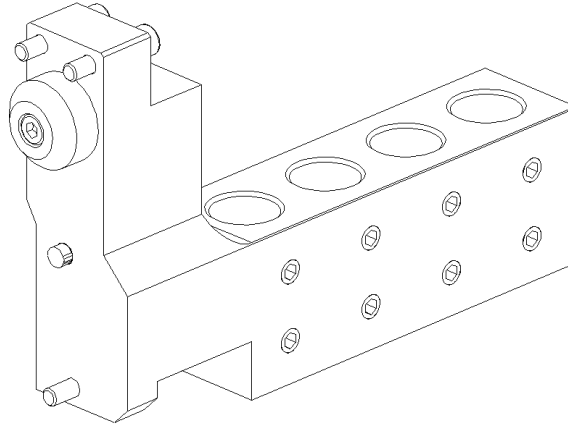
GDF1304

Machine: CITIZEN
Type: L212
Location, N°: T9-T10
Work on: Main spindle
Type of work: 
i (n_i / n₀):
Attachement: 4x Ø19.05 mm

Without coolant

Infos:

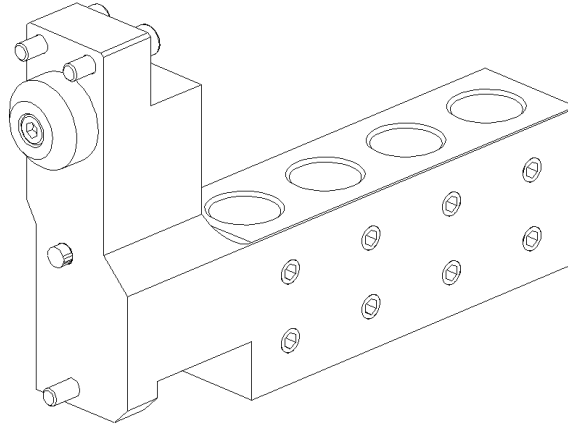
GDF1304

Maschine: CITIZEN
Typ: L212
Position, N°: T9-T10
Arbeit über: Hauptspindel
Arbeitstyp: 
i (n_i / n₀):
Befestigung: 4x Ø19.05 mm

Ohne Kühlmittel

Infos: