

Français

Matériel inclus :

- 2x D912 M5x85 Q Vis M5x85

Remarque :

Toutes les vis de fixation doivent être serrées selon les couples indiqués dans le tableau ci-dessous.

Qualité standard : **12.9**

Couples de serrage recommandés pour vis et écrous				
Diamètre	Couple de serrage en [Nm]			
	Classe 5.8	Classe 8.8	Classe 10.9	Classe 12.9
M2	0.22	0.35	0.49	0.58
M3	0.77	1.2	1.7	2.1
M4	1.8	2.9	4	4.9
M5	3.6	5.7	8.1	9.7
M6	6.1	9.8	14	17
M8	15	24	33	40

Fixation du porte-outil sur la machine

Pour fixer le porte outil, centrer la queue dans la machine et serrer les vis de fixation.

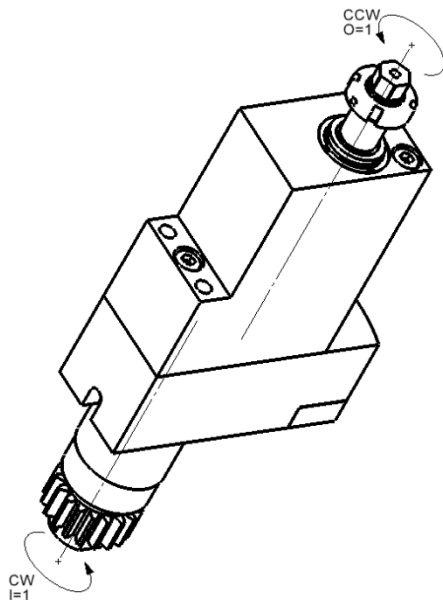

Utilisation

- Régler l'offset de la position.
- Lors du montage ou démontage de vos outils de coupe, bloquer la broche sur les plats prévus à cet effet.

GSS1235-DEC**English****Included material:**

1. 2x D912 M5x85 Q Vis M5x85

Note:

All fixing screws shall be tightened to the torques specified in the table below.

Standard quality: **12.9**

Diameter	Recommended torque for screws and bolts			
	Tightening torque [Nm]			
	Class 5.8	Class 8.8	Class 10.9	Class 12.9
M2	0.22	0.35	0.49	0.58
M3	0.77	1.2	1.7	2.1
M4	1.8	2.9	4	4.9
M5	3.6	5.7	8.1	9.7
M6	6.1	9.8	14	17
M8	15	24	33	40

Fixing the tool holder on the machine

To fix the tool holder, center the shank in the machine and tighten the fastening screws.

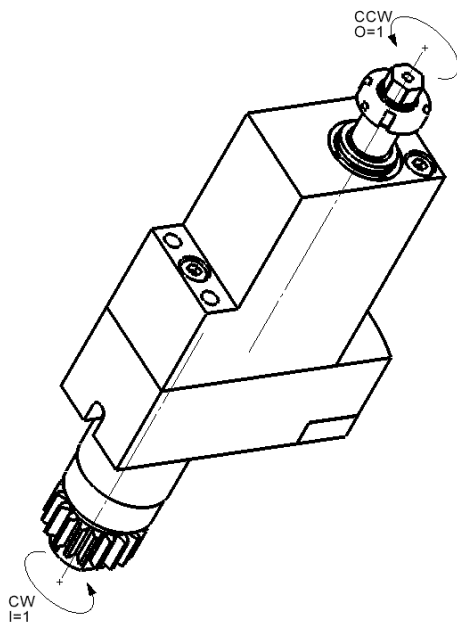
**Use**

1. Settle the offsets of the position.
2. During the assembly or the dismantling of your tools of cup, to block the brooch on dishes planned for that purpose.

GSS1235-DEC

Deutsch

Enthaltenes Material:

- 2x D912 M5x85 Q Vis M5x85

Bemerkung:

Alle Befestigungsschrauben müssen mit den in der folgenden Tabelle angegebenen Drehmomenten angezogen werden.

Standardqualität: **12.9**

Diameter	Recommended torque for screws and bolts			
	Tightening torque [Nm]			
	Class 5.8	Class 8.8	Class 10.9	Class 12.9
M2	0.22	0.35	0.49	0.58
M3	0.77	1.2	1.7	2.1
M4	1.8	2.9	4	4.9
M5	3.6	5.7	8.1	9.7
M6	6.1	9.8	14	17
M8	15	24	33	40

Befestigen des Werkzeughalters:

Um den Werkzeughalter zu befestigen, zentrieren Sie den Schaft in der Maschine und ziehen Sie die Befestigungsschrauben an.

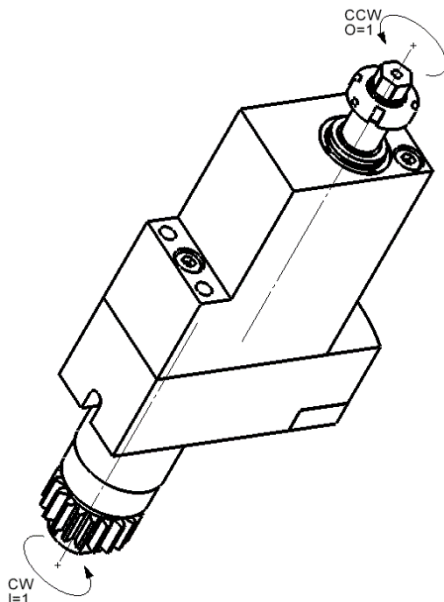

Use

- Den Offsets die Lage regulieren.
- Während der Montage oder der Demontage Ihrer Werkzeuge des Bechers, die Brosche auf den dafür vorgesehenen Tellern zu blockieren.