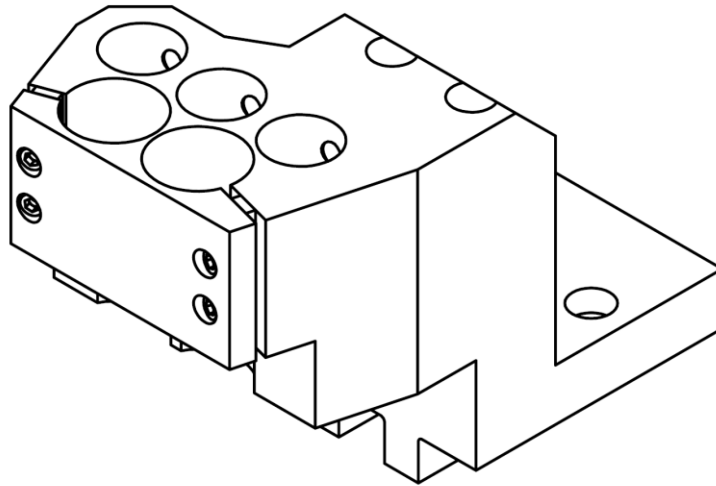

**P03-GDF-520-HF**

Machine: TSUGAMI

Type: P03

Emplacement, N°: T01+T02 / T13+T14 / T14+T15 / T15+T16 / T16+T17

Travail sur: Broche principale / Broche de reprise

Type de travail: n<sub>max</sub>: - [rpm]i (n<sub>i</sub> / n<sub>o</sub>): -

Attachement: Autre

Sans refroidissement

Infos:

- Porte-barre d'alésage
- 3xØ16 + 2xØ20
- Nakanishi BM 320

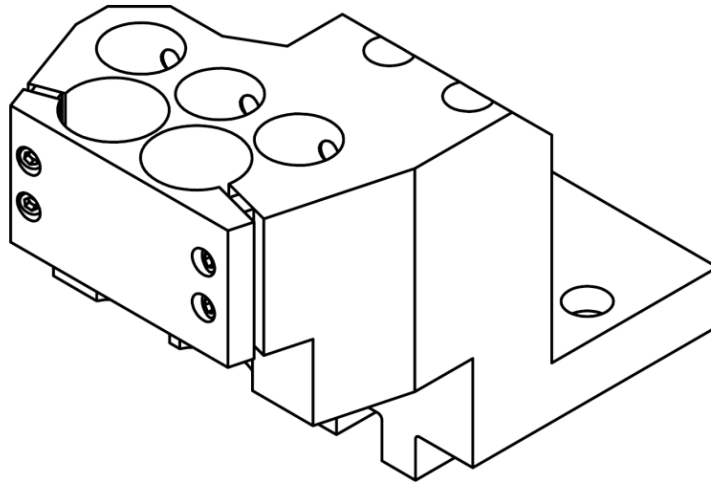
**P03-GDF-520-HF**

Machine: TSUGAMI  
Type: P03  
Location, N°: T01+T02 / T13+T14 / T14+T15 / T15+T16 / T16+T17  
Work on: Main spindle / Back spindle  
Type of work:   
n<sub>max</sub>: - [rpm]  
i (n<sub>i</sub> / n<sub>o</sub>): 1 / 1  
Attachement: Other  
Without coolan Maximum pressure: \_ [bar]

## Infos:

- Boring bar holder
- 3xØ16 + 2xØ20
- Nakanishi BM 320

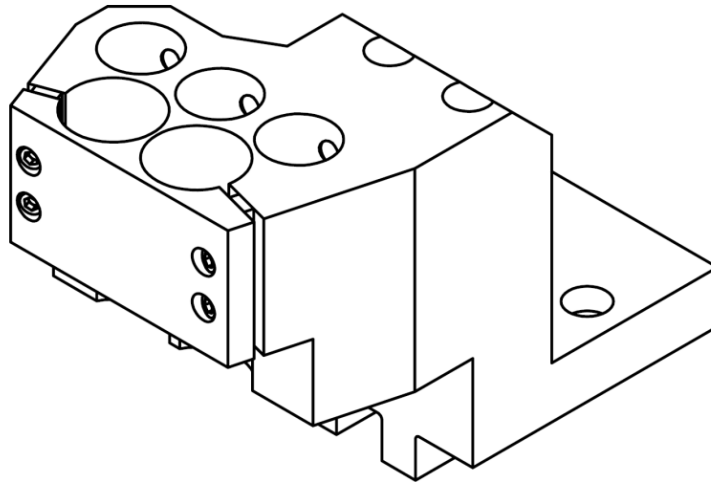
**P03-GDF-520-HF**

Maschine: TSUGAMI  
Typ: P03  
Position, N°: T01+T02 / T13+T14 / T14+T15 / T15+T16 / T16+T17  
Arbeit über: Hauptspindel / Abgreifspindel  
Arbeitstyp:   
 $n_{max}$ : - [rpm]  
 $i$  ( $n_i$  /  $n_o$ ): -  
Befestigung: Andere

Ohne Kühlmittel

Infos:

- Bohrstangenaufnahme
- 3xØ16 + 2xØ20
- Nakanishi BM 320

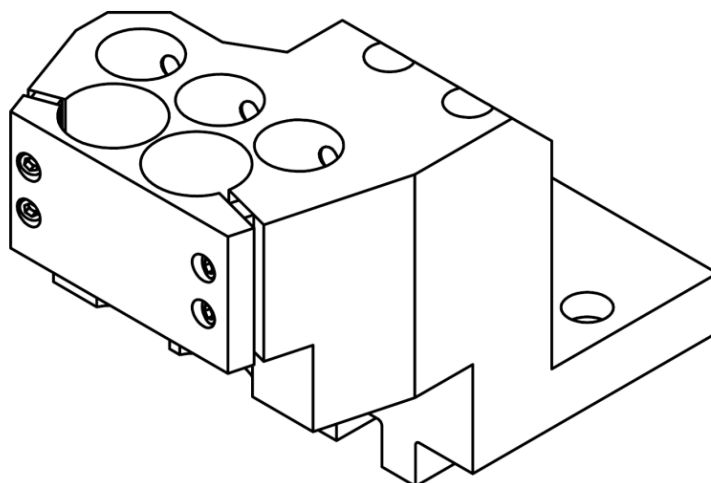
**P03-GDF-520-HF**

Macchina: TSUGAMI  
Tipo: P03  
Posizione, N°: T01+T02 / T13+T14 / T14+T15 / T15+T16 / T16+T17  
Lavoro al: Mandrino principale / Contromandrino  
Tipo di lavoro:   
 $n_{max}$ : - [rpm]  
 $i$  ( $n_i$  /  $n_o$ ): -  
Ataccamento: Altro

Senza refrigerante

Informazioni:

- Porta-barra di alesaggio
- 3xØ16 + 2xØ20
- Nakanishi BM 320