

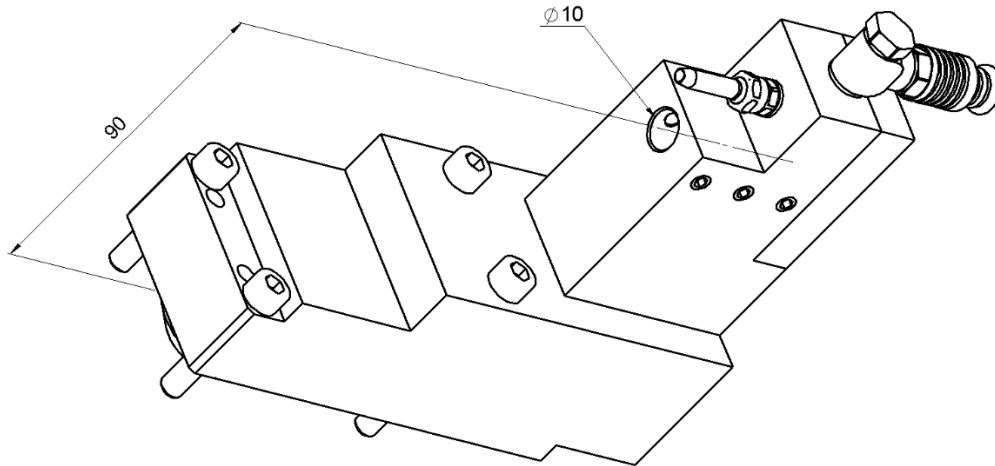

GDF102-IK

Machine: CITIZEN
Type: M32-4M7 / M32-4M8
Emplacement, N°: Back tool post
Travail sur: Broche de reprise
Type de travail: 
i (n_i / n_o): -
Attachement: Ø10

Refroidissement interne et externe, Max 150 bar

Infos:

Possibilité de choisir l'arrosage seulement interne, externe ou les deux.

Profondeur de perçage 175 mm max.

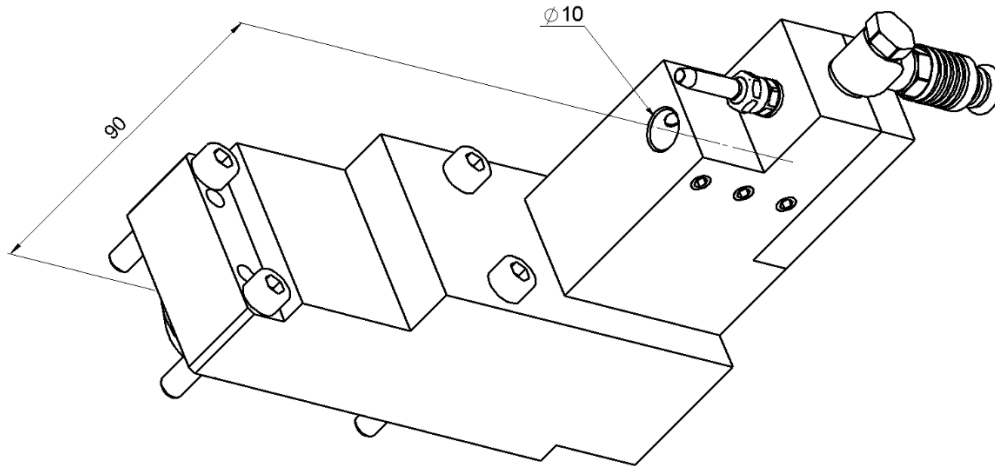
GDF102-IK

Machine: CITIZEN
Type: M32-4M7 / M32-4M8
Location, N°: Back tool post
Work on: Back spindle
Type of work: 
i (n_i / n_o): -
Attachement: Ø10

Internal and external coolant, max 150 bar

Infos:

Possibility to choose coolant between internal, external or both.

Drilling depth 175 mm max.

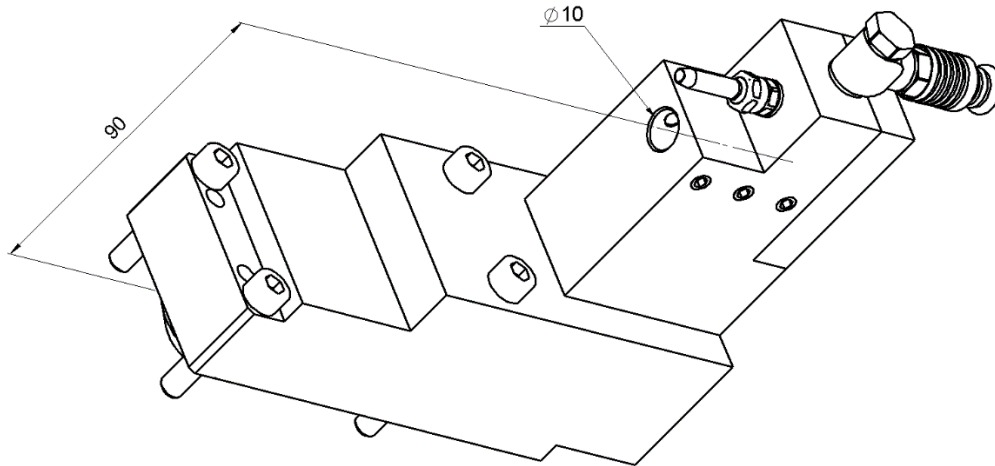
GDF102-IK

Maschine: CITIZEN
Typ: M32-4M7 / M32-4M8
Position, N°: Back tool post
Arbeit über: Abgreifspindel
Arbeitstyp: 
i (n_i / n_o): -
Befestigung: Ø10

Innere und ausser Kühlmittel, Max 150 bar

Infos:

Es besteht die Möglichkeit, zwischen internem, externem oder beidem Kühlmittel zu wählen.

Bohrtiefe 175 mm max.