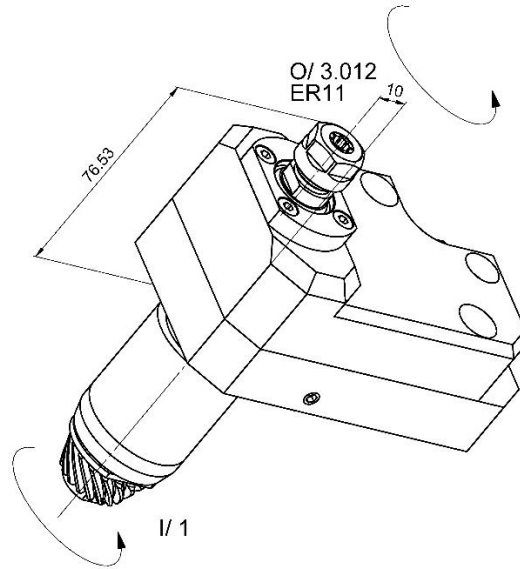

KSC-DEC-10x3

Machine: CITIZEN Cincom

Type: M220-III/V M232-III/V M320-III/V M3232-III/V M32-4M5

Emplacement, N°: T20-T29

Travail sur: Broche principale / Broche de reprise

Type de travail: n_{max}: 15'060 [rpm]i (n_i / n_o): 1 / 3.012

Attachement: ER 11

Refroidissement externe

Infos :

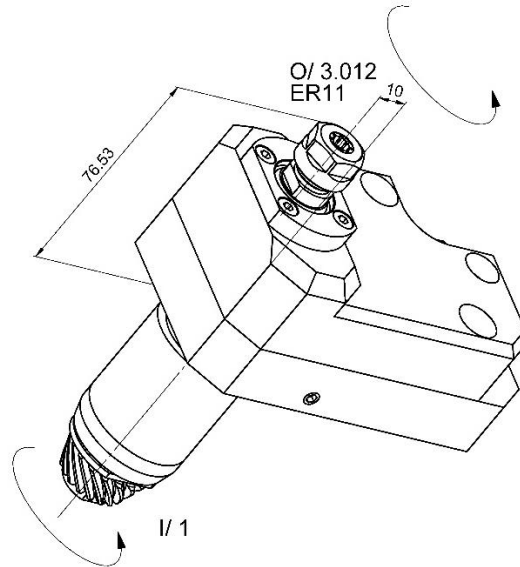
KSC-DEC-10x3

| | |
|----------------------|---|
| Machine: | CITIZEN Cincom |
| Type: | M220-III/V M232-III/V M320-III/V M3232-III/V M32-4M5 |
| Location, N°: | T20-T29 |
| Work on: | Main spindle / Back spindle |
| Type of work: |  |
| n_{max} : | 15'060 [rpm] |
| i (n_i / n_o): | 1 / 3.012 |
| Attachement: | ER 11 |
| External coolant | |
| Infos : | |

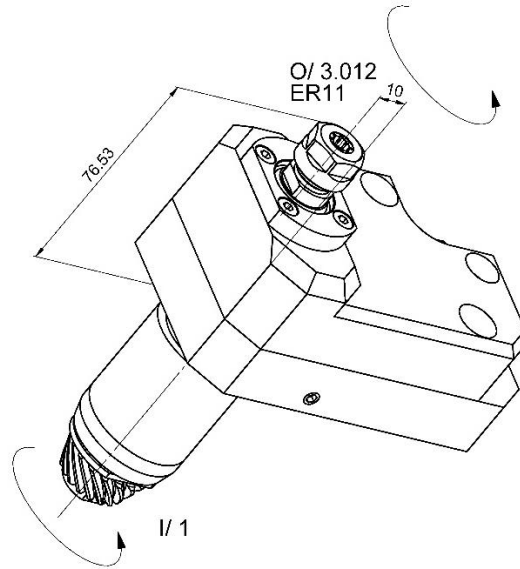
KSC-DEC-10x3

Maschine: CITIZEN Cincom
Typ: M220-III/V M232-III/V M320-III/V M3232-III/V M32-4M5
Position, N°: T20-T29
Arbeit über: Hauptspindel / Abgreifspindel
Arbeitstyp: 
n_{max}: 15'060 [rpm]
i (n_i / n_o): 1 / 3.012
Befestigung: ER 11
Ausser Kühlmittel
Infos:

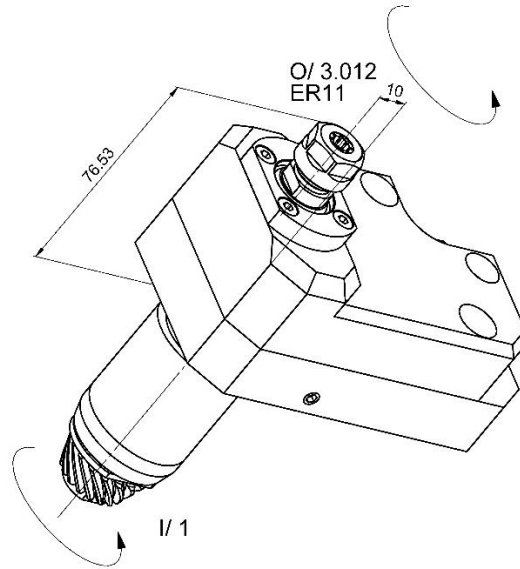
KSC-DEC-10x3

Macchina: CITIZEN Cincom
Tipo: M220-III/V M232-III/V M320-III/V M3232-III/V M32-4M5
Posizione, N°: T20-T29
Lavoro al: Mandrino principale / Contromandrino
Tipo di lavoro: 
n_{max}: 15'060 [rpm]
i (n_i / n_o): 1 / 1
Atacco: ER 11
Refrigerante esterno
Informazioni: