

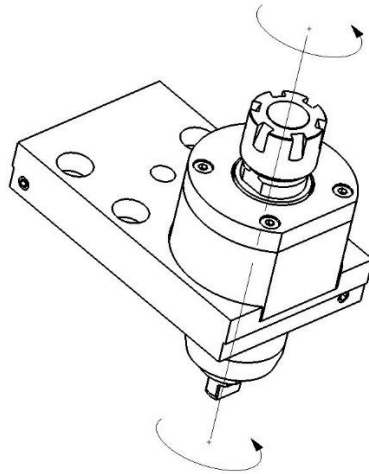





KSC113

Machine: Citizen
Type: M532
Emplacement, N°: T20-T29, T40-49
Travail sur: Broche principale, broche de reprise
Type de travail: 
 n_{max} : 6'000 [rpm]
 i (n_i / n_o): 1 / 1
Attachement: ER20
Refroidissement externe
Pression maximale: 150 [bar]

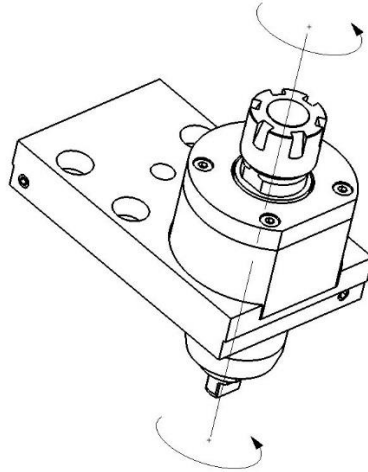
KSC113

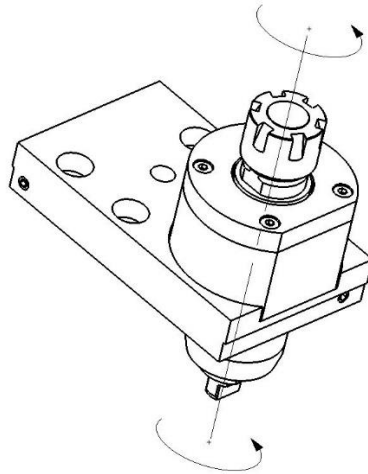
Machine: Citizen
Type: M532
Location, N°: T20-T29, T40-T49
Work on: Main spindle, Back spindle
Type of work: 
 n_{max} : 6'000 [rpm]
 $i (n_i / n_o)$: 1 / 1
Attachement: ER20
Extern coolant
Maximum pressure: 150 [bar]

KSC113

Maschine: Citizen
Typ: M532
Position, N°: T20-T29, T40-T49
Arbeit über: Hauptspindel, Abgreifspindel
Arbeitstyp: 
 n_{max} : 6'000 [rpm]
 i (n_i / n_o): 1 / 1
Befestigung: ER20
Ausser Kühlmittel
Maximaler Drück: 150 [bar]

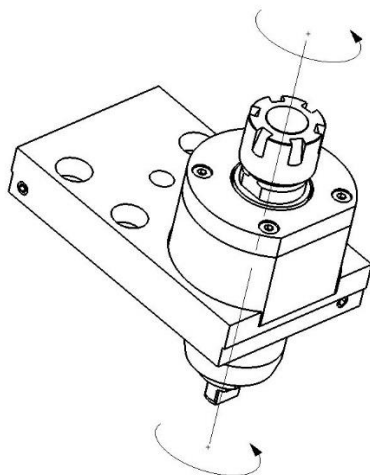
KSC113

Macchina: Citizen
Tipo: M532
Posizione, N°: T20-T29, T40-T49
Lavoro al: Mandrino principale, Contromandrino
Tipo di lavoro: 
 n_{max} : 6'000 [rpm]
 i (n_i / n_o): 1 / 1
Ataccamento: ER20
Refrigerante esterno
Pressione massima: 150 [bar]