

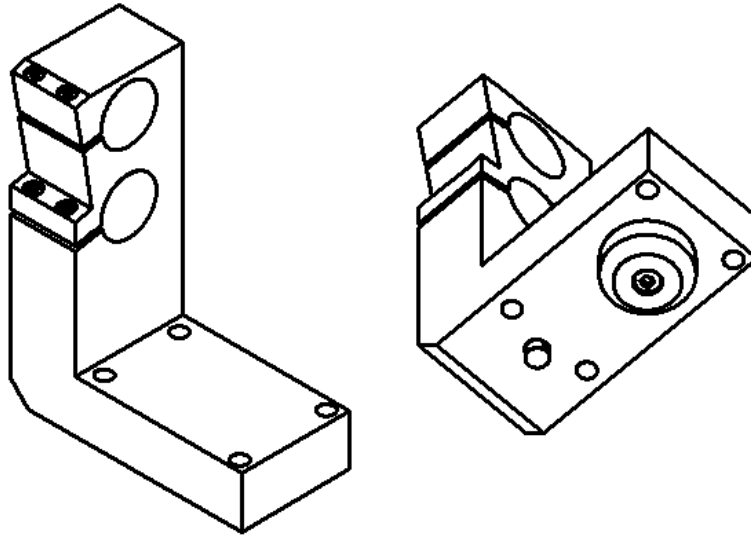

GDF1601-HF

Machine: CITIZEN Cincom

Type: L32

Emplacement, N°: GDF1601

Travail sur: Broche principale / Broche de reprise



Type de travail:   n_{\max} : - [rpm]i (n_i / n_o): -/-

Attachement: 2x Ø25H5

Sans refroidissement Pression maximale: _ [bar]

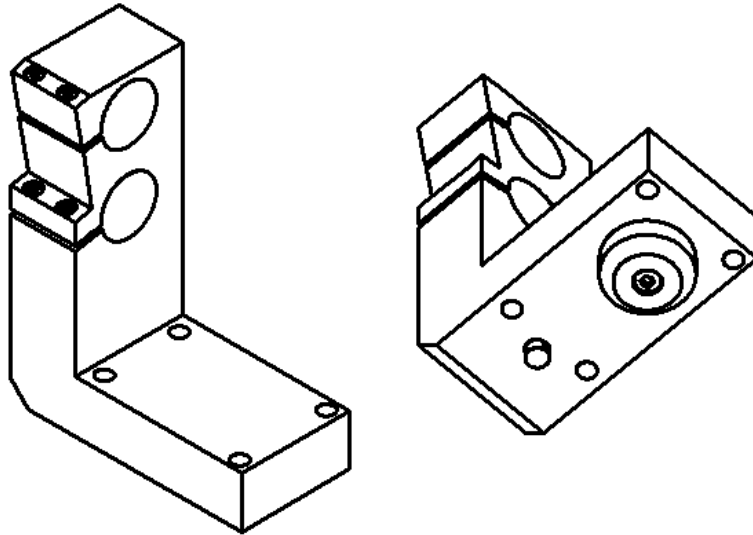
Infos: Support pour outils non-entraînés

GDF1601-HF

Machine: CITIZEN Cincom
Type: L32
Location, N°: GDF1601
Work on: Main spindle / Back spindle
Type of work:  
 n_{max} : - [rpm]
 $i (n_i / n_o)$: 1 / 1
Attachement: 2x Ø25H5
Without coolan Maximum pressure: _ [bar]
Infos: Tool holder without power transmission

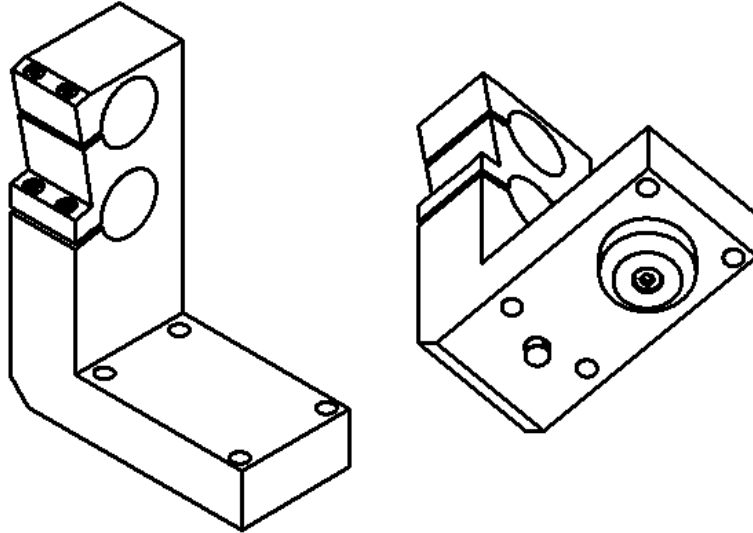
GDF1601-HF

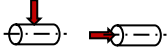
Maschine: CITIZEN Cincom
Typ: L32
Position, N°: GDF1601
Arbeit über: Hauptspindel / Abgreifspindel
Arbeitstyp: 
 n_{max} : - [rpm]
 $i (n_i / n_o)$: 1 / 1
Befestigung: 2x Ø25H5
Ohne Kühlmittel Drück: _ [bar]
Infos: Werkzeughalter ohne Kraftübertragung

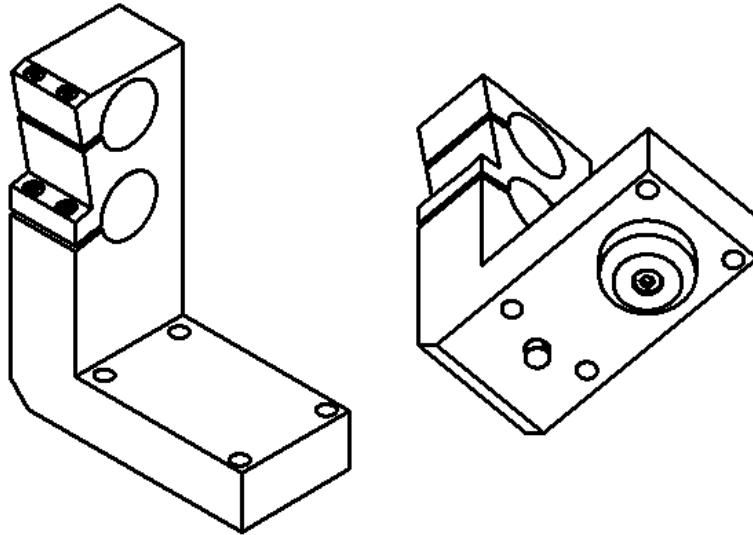
GDF1601-HF

Macchina: CITIZEN Cincom
Tipo: L32
Posizione, N°: GDF1601
Lavoro al: Mandrino principale / Contromandrino
Tipo di lavoro: 
 n_{max} : - [rpm]
 $i (n_i / n_o)$: 1 / 1
Ataccamento: 2x Ø25H5

Senza refrigerante Pressione massima: _ [bar]

Informazioni: Supporto per utensili non motorizzati