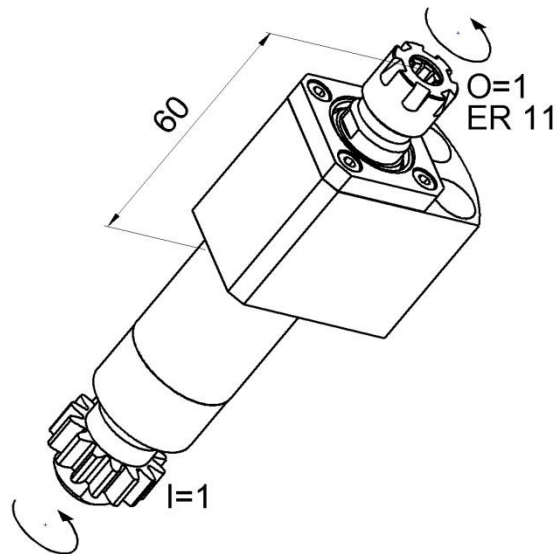

GSC-907

Machine: CITIZEN Cincom

Type: L20E

Emplacement, N°: Tourrelle / Coulisse linéaire / Unité d'usinage de reprise / Autre, T06 / T07

Travail sur: Broche principale / Broche de reprise

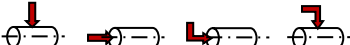
Type de travail:  n_{max} : 5'000 [rpm] i (n_i / n_o): 1 / 1

Attachement: ER 11 / Arbre Ø _ / Autre

Sans refroidissement / Refroidissement externe / Refroidissement interne Pression
maximale: _ [bar]

Infos:

GSC-907

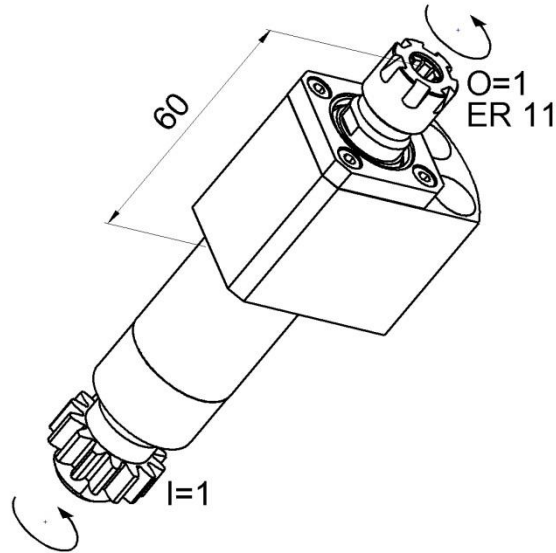

Machine: CITIZEN Cincom
 Type: L20E
 Location, N°: Turret / Gangtool / Back tool post / Other, T06 / T07
 Work on: Main spindle / Back spindle
 Type of work: 
 n_{max} : 5'000 [rpm]
 $i (n_i / n_o)$: 1 / 1
 Attachement: ER 11 / Arbor \varnothing _ / Other
 Without coolant / External coolant / Internal coolant Maximum pressure: _ [bar]
 Infos:

GSC-907

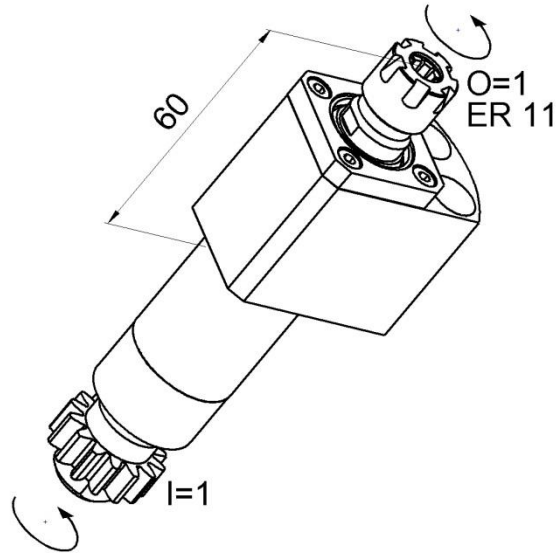

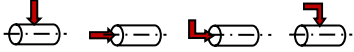
Maschine: CITIZEN Cincom
 Typ: L20E
 Position, N°: Revolver / Vertikalhalter / Rückseitenbearbeitung / Andere, T06 / T07
 Arbeit über: Hauptspindel / Abgreifspindel
 Arbeitstyp: 
 n_{max} : 5'000 [rpm]
 $i (n_i / n_o)$: 1 / 1
 Befestigung: ER 11 / Welle \emptyset _ / Andere
 Ohne Kühlmittel / Ausser Kühlmittel / Inner Kühlmittel Maximaler Druck: _ [bar]
 Infos:

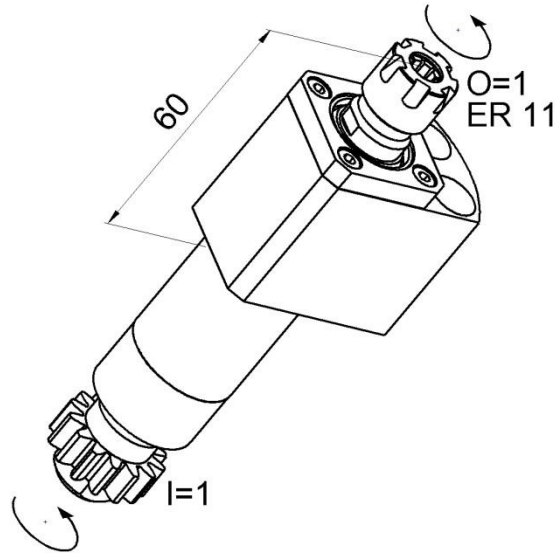
GSC-907

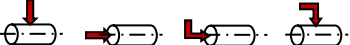
Macchina:	CITIZEN Cincom		
Tipo:	L20E		
Posizione, N°:	Toretta / Slitta lineare / Unità di lavoro posteriore / Altro, T06 / T07		
Lavoro al:	Mandrino principale / Contromandrino		
Tipo di lavoro:			
n_{max} :	5'000 [rpm]		
$i (n_i / n_o)$:	1 / 1		
Ataccamento:	ER 11 / Albero Ø _ // Altro		
Senza refrigerante / Refrigerante esterno / Refrigerante interno	Pressione massima: _ [bar]		
Informazioni:			