

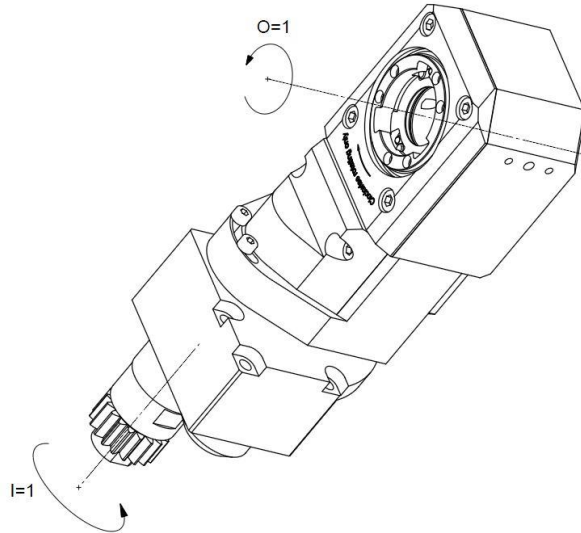

GSW-160

Machine: CITIZEN Cincom
Type: M32-4M3/5/7/8, M32-5M5/7/8
Emplacement, N°: Upper gang tool post
Travail sur: Broche principale
Type de travail: 
i (n_i / n_o): 1 / 1
Attachement: Tête porte-plaquettes

Sans refroidissement

Infos:

- Utilise 2 positions d'outils
- Seulement T06/T07 pour M32-5M5/7
- Inclinaison : 16°
- Têtes compatibles avec fixation rapide : Gloor (couteaux ronds), Schwanog (couteaux triangulaires) et Horn (couteaux triangulaires), Ø de passage 8, 11, 12mm.

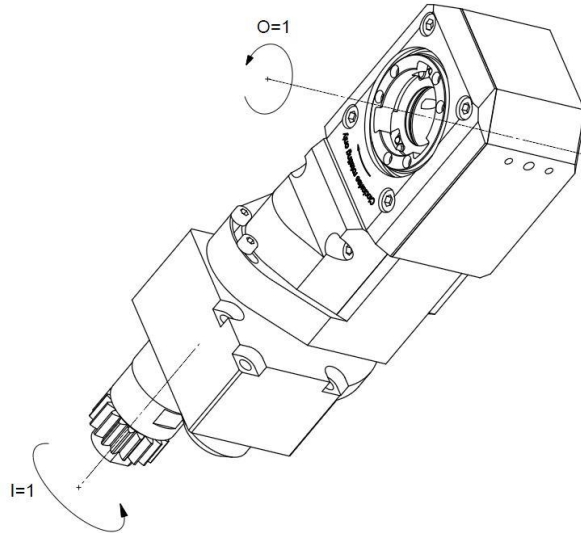
GSW-160

Machine: CITIZEN Cincom
Type: M32-4M3/5/7/8, M32-5M5/7/8
Location, N°: Upper gang tool post
Work on: Main spindle
Type of work: 
i (n_i / n_o): 1 / 1
Attachement: Whirling head

Without coolant

Infos:

- Uses 2 tool positions.
- Only T06/T07 for M32-5M5/7.
- Inclination : 16°
- Compatible heads with quick attachment : Gloor (round cutters), Schwanog (triangular cutters) and Horn (triangular cutters), passing Ø 8, 11, 12mm.

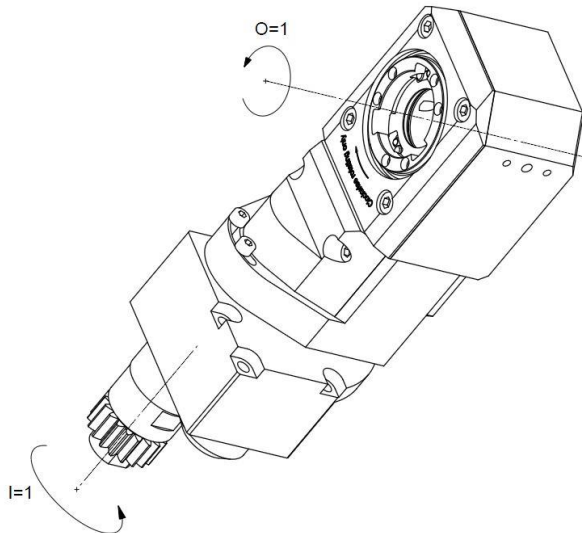
GSW-160

Maschine: CITIZEN Cincom
Typ: M32-4M3/5/7/8, M32-5M5/7/8
Position, N°: Upper gang tool post
Arbeit über: Hauptspindel
Arbeitstyp: 
i (n_i / n_o): 1 / 1
Befestigung: Wirbelkopf

Ohne Kühlmittel

Infos:

- Verwendet 2 Werkzeugpositionen
- Nur T06/T07 für M32-5M5/7
- Neigungswinkel : 16°
- Kompatibel Wirbelköpfe mit Schnellbefestigung : Gloor (Zirkularplatten), Schwanog (Dreikantplatten) und Horn (Dreikantplatten), DurchführungsØ 8, 11, 12mm.

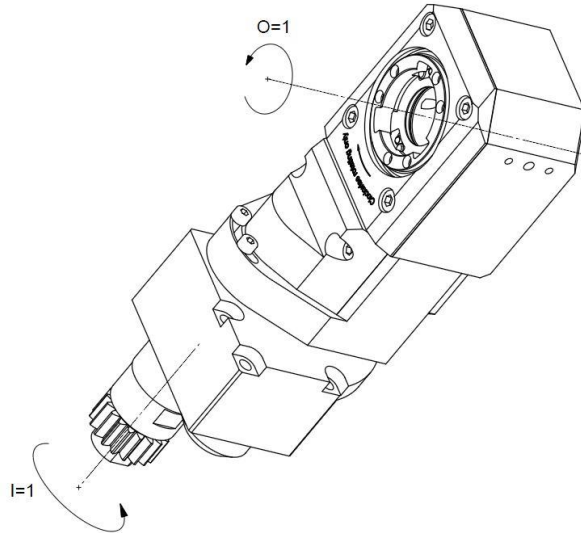
GSW-160

Macchina: CITIZEN Cincom
Tipo: M32-4M3/5/7/8, M32-5M5/7/8
Posizione, N°: Upper gang tool post
Lavoro al: Mandrino principale
Tipo di lavoro: 
i (n_i / n_o): 1 / 1
Ataccamento: Disco per discofilletatura

Senza refrigerante

Informazioni:

- Utilizza 2 posizioni di utensili.
- Solo T06/T07 per M32-5M5/7.
- Inclinazione : 16°
- Dischi compatibili con attacchi veloce : Gloor (inserti circolari), Schwanog (inserti triangolare) e Horn (inserti triangolare), Ø di passaggio 8m, 11, 12mm.