

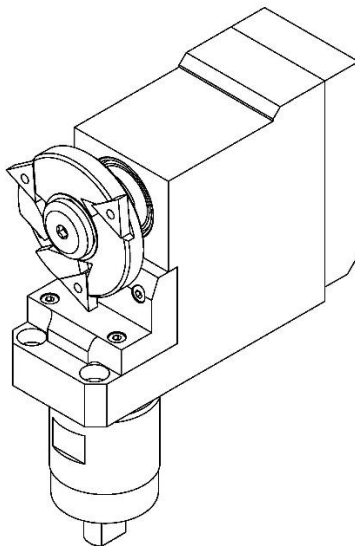

0400-SP130-R00000-1S02

Machine: TSUGAMI
Type: BO7 II, BO12 II, BO20 II
Emplacement, N°: Front gang tool post
Travail sur: Broche principale
Type de travail: 
i (n_i / n_o): 1 / 1
Attachement: Arbre Ø 13

Sans refroidissement

Infos: Porte-outil pour polygonage

Fraise disque utilisée, $\varnothing_{\max}=72\text{mm}$, Largeur= L = 8.3 mm

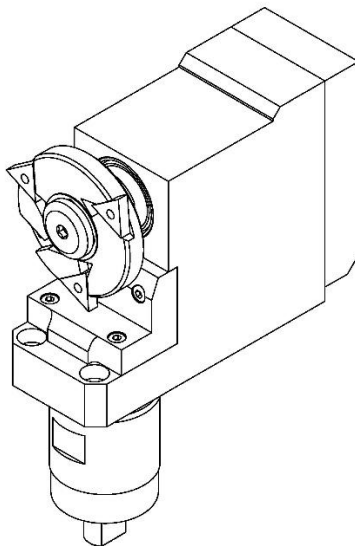
0400-SP130-R00000-1S02

Machine: TSUGAMI
Type: BO7 II, BO12 II, BO20 II
Location, N°: Front gang tool post
Work on: Main spindle
Type of work: 
i (n_i / n_o): 1 / 1
Attachement: Shaft Ø 13

Without coolant

Infos: Driven toolholder for polygon milling

Milling cutters, $\varnothing_{\max}=72\text{mm}$, Width= L = 8.3 mm

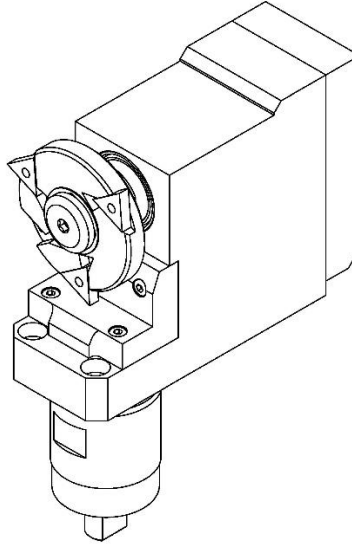
0400-SP130-R00000-1S02

Maschine: TSUGAMI
Typ: BO7 II, BO12 II, BO20 II
Position, N°: Front gang tool post
Arbeit über: Hauptspindel
Arbeitstyp: 
i (n_i / n_o): 1 / 1
Befestigung: Welle Ø 13

Ohne Kühlmittel

Infos: Angetriebener Fräserhalter für Vieleck

Polygonfräser, $\varnothing_{\max}=72\text{mm}$, Breite = L = 8.3 mm