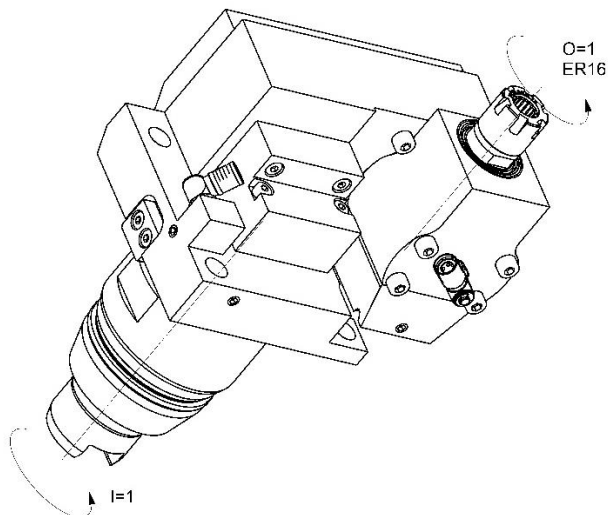

0400-SC016-RADAH0-1S01

Machine: TSUGAMI

Type: M08SY-2

Emplacement, N°: Turret

Travail sur: Broche de reprise

Type de travail:

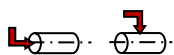
i (n_i / n_o): 1 / 2

Attachement: ER 16

Refroidissement interne Pression maximale: 100 [bar]

Infos: Une huile filtrée à 50µm est nécessaire.

Degré d'inclinaison 0°-90°

0400-SC016-RADAH0-1S01

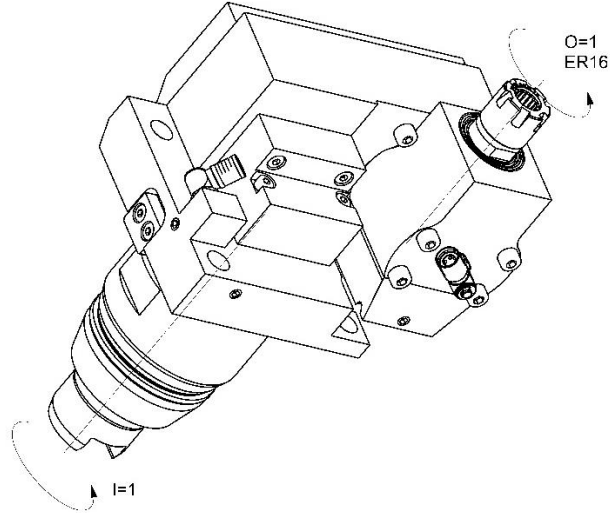

Machine: TSUGAMI

Type: M08SY-2

Location, N°: Turret

Work on: Back spindle

Type of work: 

i (n_i / n_o): 1 / 2

Attachement: ER 16

Internal coolant Maximum pressure: 100 [bar]

Infos: There is a need for an oil filtered at 50µm.

Degree of inclination 0°-90°

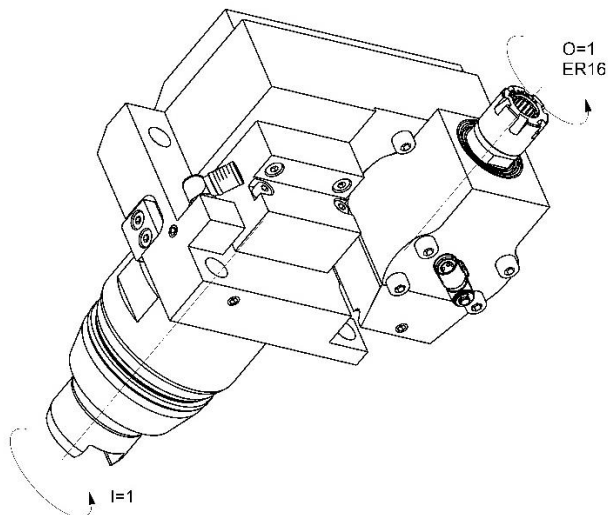
0400-SC016-RADAH0-1S01

Machine: TSUGAMI

Typ: M08SY-2

Position, N°: Turret

Arbeit über: Abgreifspindel

Arbeitstyp:

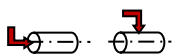
i (n_i / n_o): 1 / 2

Befestigung: ER 16

Inner Kühlmittel Maximaler Drück: 100 [bar]

Infos: Es besteht Bedarf an einem auf 50µm gefilterten Öl.

Grad der Neigung 0°-90°