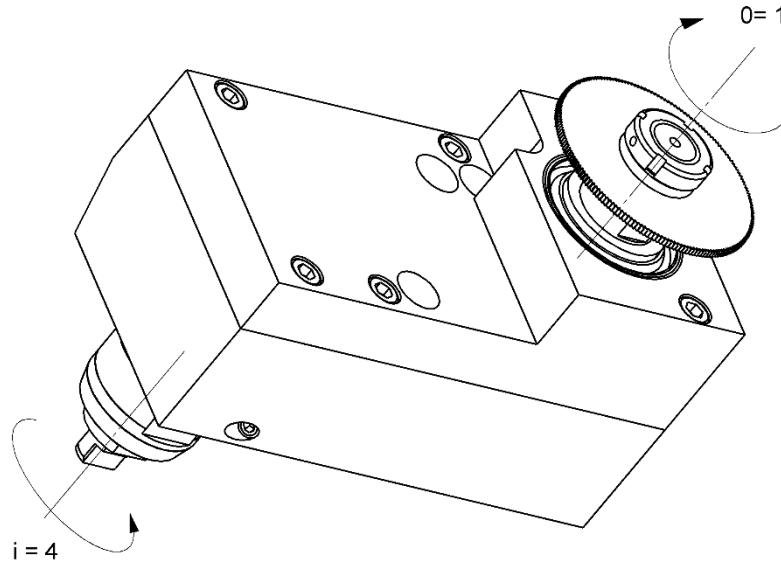

KSS1063

Machine: CITIZEN

Type: M532

Emplacement, N°: Turret

Travail sur: Broche principale

Type de travail: i (n_i / n_o): 4 / 1

Attachement: Arbre Ø 16

Refroidissement externe Pression maximale : 150 [bar]

Infos:

Scie Ø63 mm, épaisseur 1-4 mm

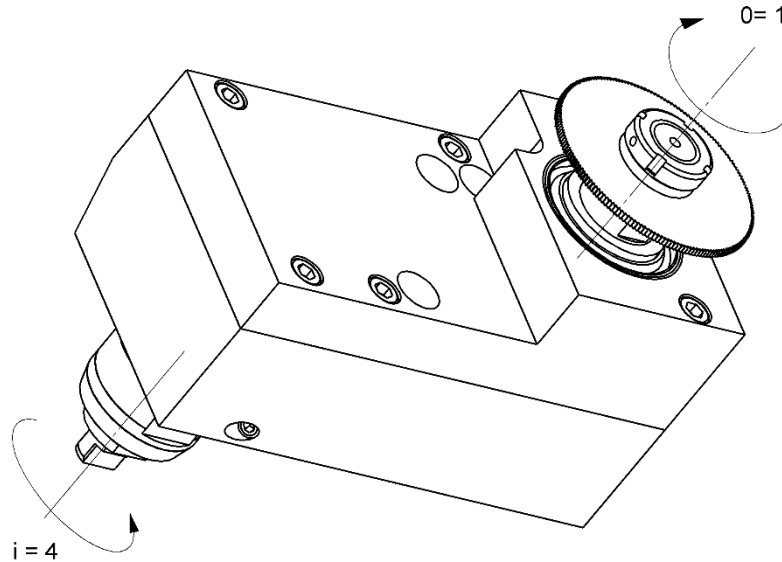
KSS1063

Machine: CITIZEN
Type: M532
Location, N°: Turret
Work on: Main spindle / Back spindle
Type of work: 
i (n_i / n_o): 4 / 1
Attachement: Arbor Ø16

External coolant Maximum pressure: 150 [bar]

Infos:

Saw Ø63 mm, thickness: 1-4 mm

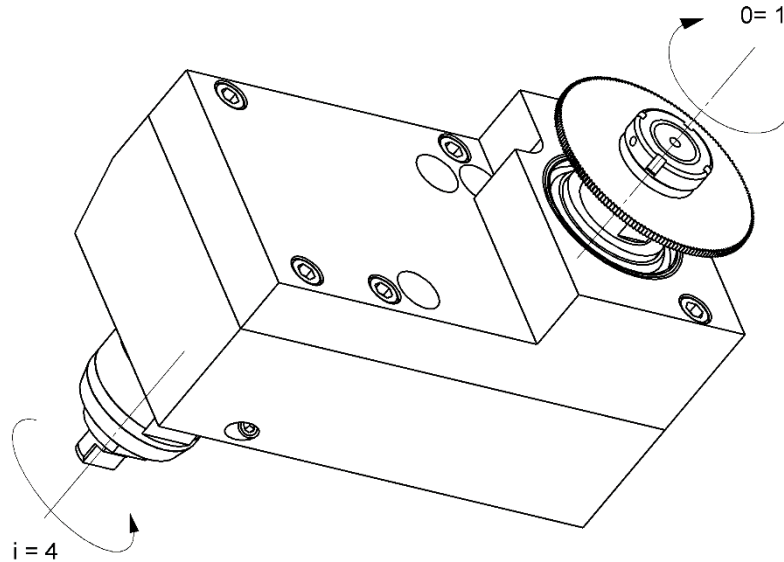
KSS1063

Machine: CITIZEN

Typ: M532

Position, N°: Turret

Arbeit über: Hauptspindel

Arbeitstyp: i (n_i / n_o): 4 / 1

Befestigung: Welle Ø16

Ausser Kühlmittel Maximaler Druck: 150 [bar]

Infos:

Säge Ø63 mm, Dicke: 1-4 mm