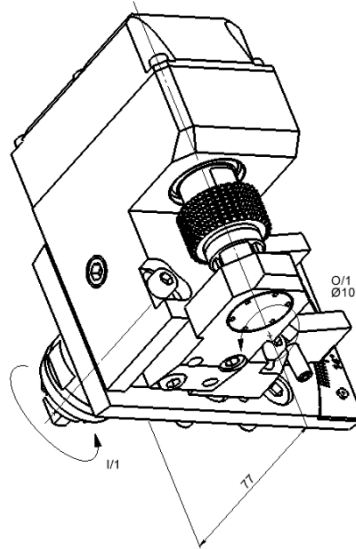

KSH432-22

Machine: CITIZEN Cincom

Type: M532

Emplacement, N°: Tourrelle

Travail sur: Broche principale

Type de travail: n_{max}: 6'000 [rpm]i (n_i / n_o): 1 / 1

Attachement: Arbre Ø 10

Sans refroidissement

Infos: fraise Ø32/10 x 20

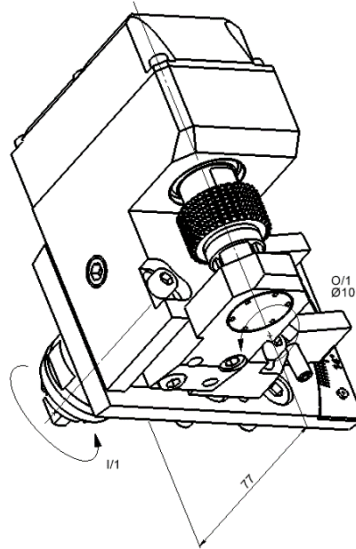
KSH432-22

Machine: CITIZEN Cincom

Type: M532

Location, N°: Turret

Work on: Main spindle

Type of work: n_{max}: 6'000 [rpm]i (n_i / n_o): 1 / 1

Attachement: Arbor Ø 10

Without coolant

Infos: Milling cutter Ø32/10 x 20

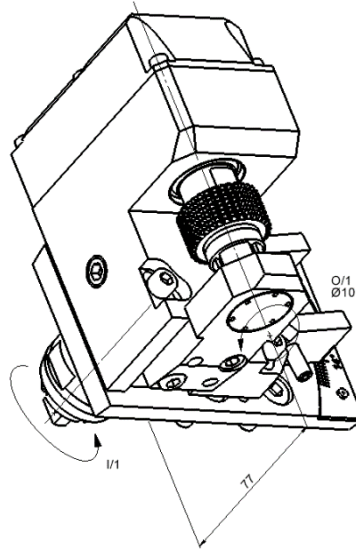
KSH432-22

Machine: CITIZEN Cincom

Typ: M532

Position, N°: Revolver

Arbeit über: Hauptspindel

Arbeitstyp: n_{max}: 6'000 [rpm]i (n_i / n_o): 1 / 1

Befestigung: Welle Ø 10

Ohne Kühlmittel

Infos:Fräswerkzeug Ø32/10 x 20

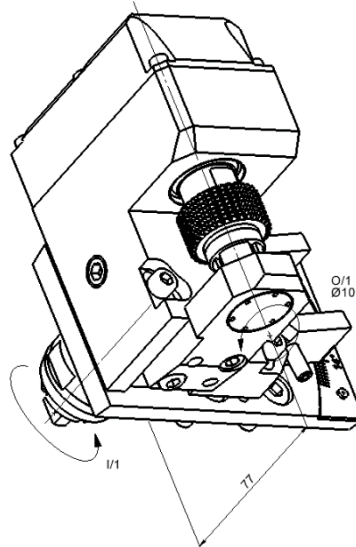
KSH432-22

Macchina: CITIZEN Cincom
Tipo: M532
Posizione, N°: Toretta
Lavoro al: Mandrino principale
Tipo di lavoro: 
n_{max}: 6'000 [rpm]
i (n_i / n_o): 1 / 1
Ataccamento: Albero Ø 10
Senza refrigerante
Informazioni: fresa Ø32/10 x 20