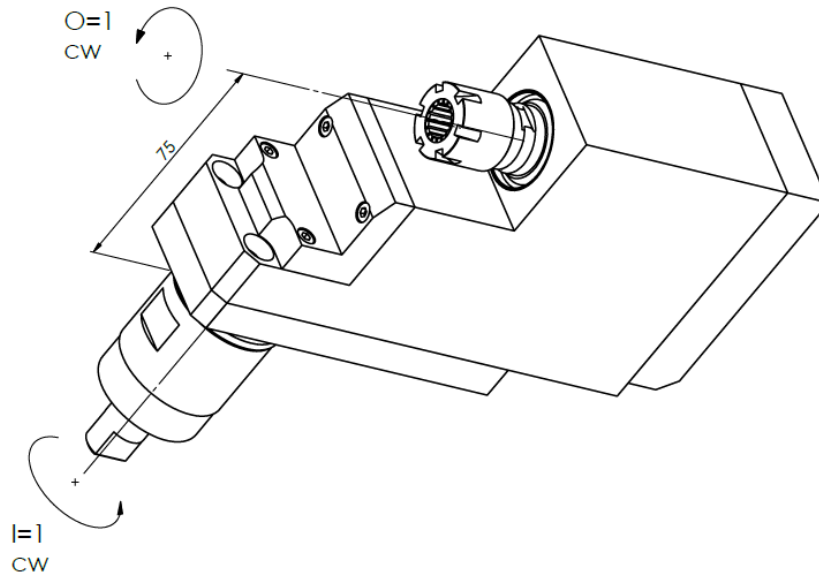

S20-RSS-110-II

Machine: Tsugami

Type: S206

Emplacement, N°: Coulisse linéaire, T11

Travail sur: Broche principale

Type de travail:  n_{\max} : 8'000 [rpm] i (n_i / n_o): 1 / 1

Attachement: ER 16

Sans refroidissement

Infos:

- Fraise scie, fraise T, etc.
- $\varnothing=10\dots70\text{mm}$

S20-RSS-110-II

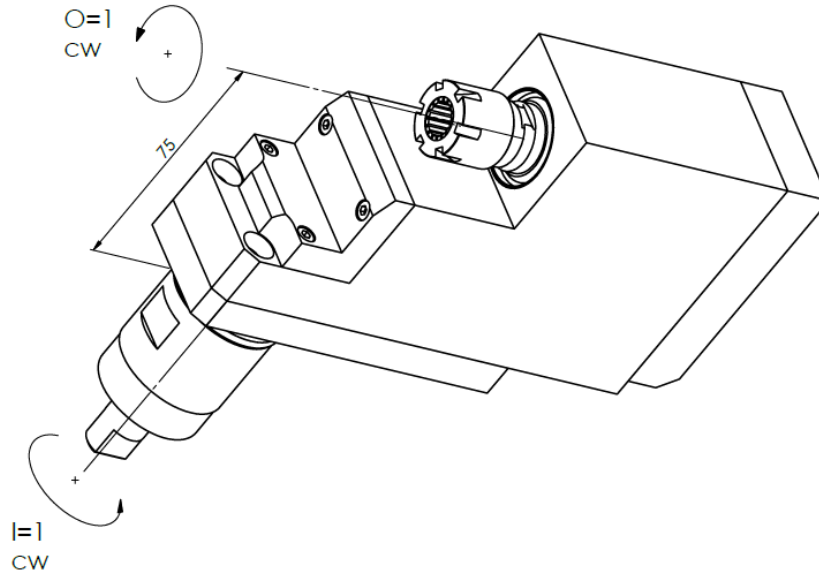



Machine: Tsugami
 Type: S206
 Location, N°: Gangtool, T11
 Work on: Main spindle
 Type of work: 
 n_{max} : 8'000 [rpm]
 $i (n_i / n_o)$: 1 / 1
 Attachement: ER 16

Without coolant

Infos:

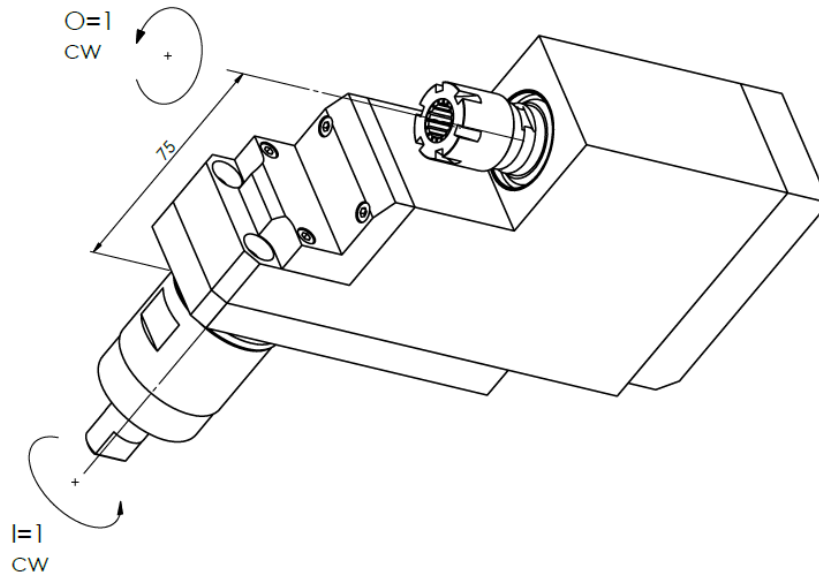
- Milling cutter
- $\varnothing=10...70\text{mm}$

S20-RSS-110-II

Maschine: Tsugami
Typ: S206
Position, N°: Vertikalhalter, T11
Arbeit über: Hauptspindel
Arbeitstyp: 
 n_{\max} : 8'000 [rpm]
 $i (n_i / n_o)$: 1 / 1
Befestigung: ER 16

Ohne Kühlmittel

Infos:

- $\varnothing=10\text{...}70\text{mm}$

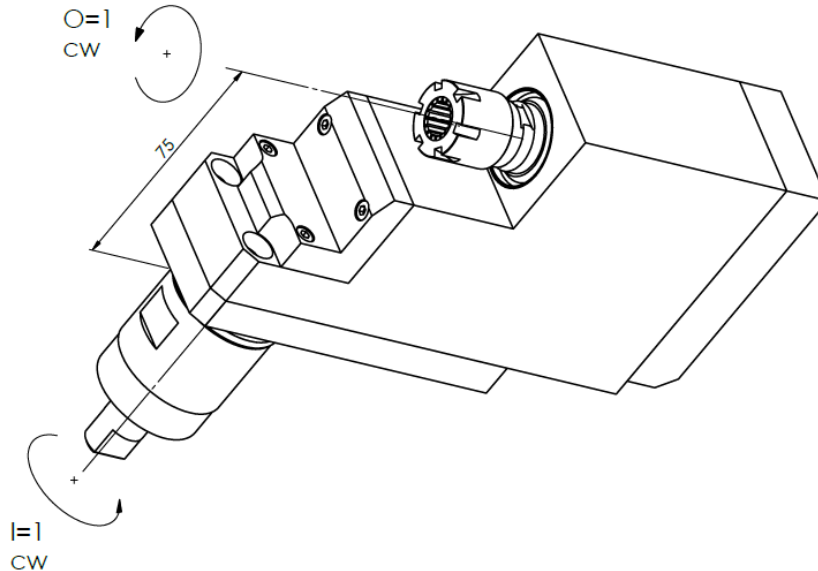
S20-RSS-110-II

Macchina: Tsugami
Tipo: S206
Posizione, N°: Slitta lineare, T11
Lavoro al: Mandrino principale
Tipo di lavoro: 
 n_{max} : 8'000 [rpm]
 $i (n_i / n_o)$: 1 / 1
Ataccamento: ER 16

Senza refrigerante

Informazioni:

- $\varnothing=10...70\text{mm}$