

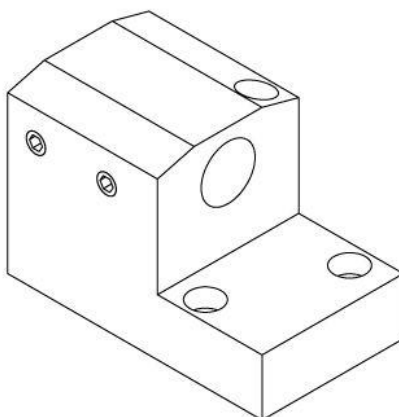



VDF-201

Machine: CITIZEN Cincom
Type: M12/M16
Emplacement, N°: Tourelle
Travail sur: Broche principale / Broche de reprise
Type de travail: 
n_{max}: - [rpm]
i (n_i / n_o): -
Attachement: Arbre Ø19.05
Refroidissement interne
Pression maximale: 150 [bar]
Infos:

VDF-201

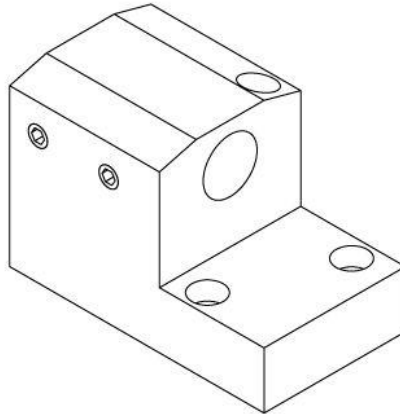
Machine: CITIZEN Cincom
Type: M12/M16
Location, N°: Turret
Work on: Main spindle / Back spindle
Type of work: 
n_{max}: - [rpm]
i (n_i / n_o): -
Attachement: Shaft Ø19.05
Internal coolant
Maximum pressure: 150 [bar]
Infos:

VDF-201

Maschine: CITIZEN Cincom
Typ: M12/M16
Position, N°: Revolver
Arbeit über: Hauptspindel / Abgreifspindel
Arbeitstyp: 
n_{max}: - [rpm]
i (n_i / n_o): -
Befestigung: Welle Ø19.05
Inner Kühlmittel
Maximaler Druck: 150 [bar]
Infos:

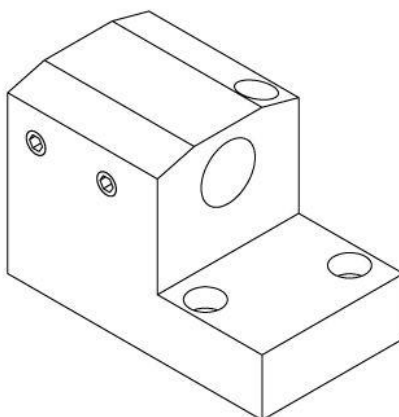
VDF-201

Macchina: CITIZEN Cincom
Tipo: M12/M16
Posizione, N°: Toretta
Lavoro al: Mandrino principale / Contromandrino
Tipo di lavoro: 
n_{max}: - [rpm]
i (n_i / n_o): -
Ataccamento: Albero Ø19.05
Refrigerante interno
Pressione massima: 150 [bar]
Informazioni: