

## KSS663-II

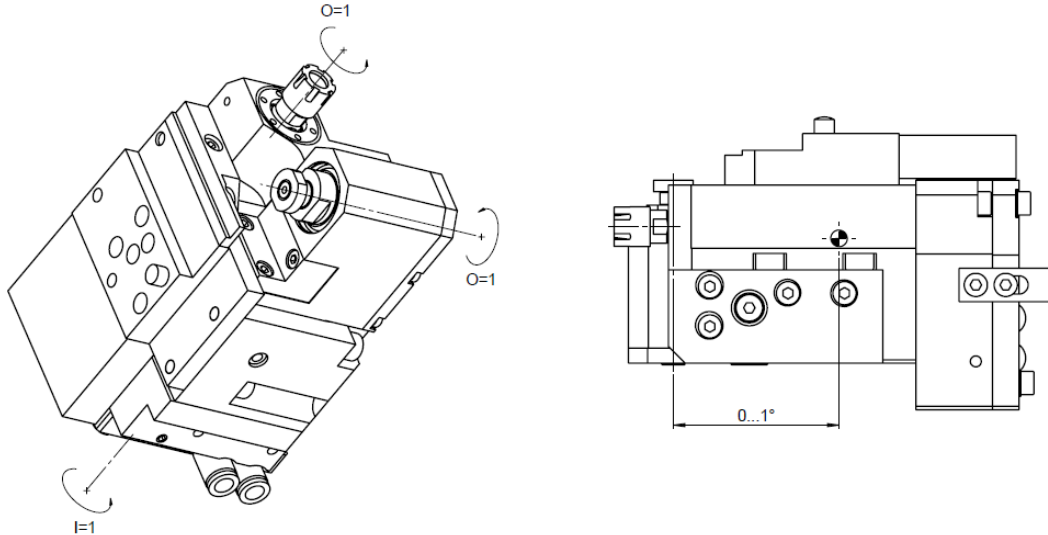



Machine: CITIZEN

Type: R504

Emplacement, N°: Front gang tool post

Travail sur: Broche principale

Type de travail:  

i (n<sub>i</sub> / n<sub>o</sub>): 1 / 1

Attachement: ER 11 / Arbre Ø 8 mm



Refroidissement du porte-outil par l'huile.

Infos:

- L'arbre Ø8 mm est inclinable jusqu'à 1°.
- Utiliser le moteur et les protections de l'outil U30B.

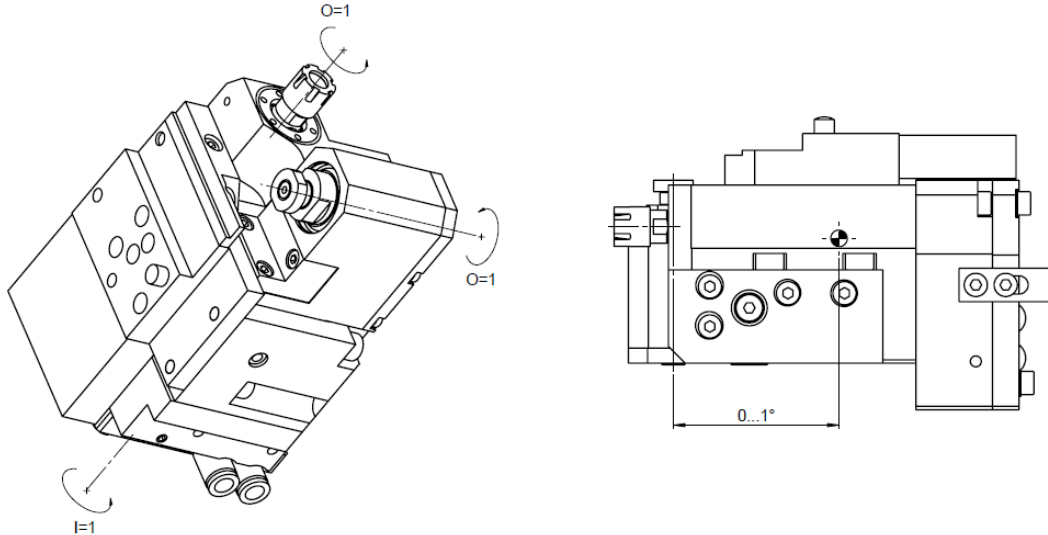
## KSS663-II





Machine: CITIZEN  
Type: R504  
Location, N°: Front gang tool post  
Work on: Main spindle  
Type of work:    
i (n<sub>i</sub> / n<sub>o</sub>): 1 / 1  
Attachement: ER11 / Arbor Ø 8 mm

Tool holder cooled by oil.

### Infos:

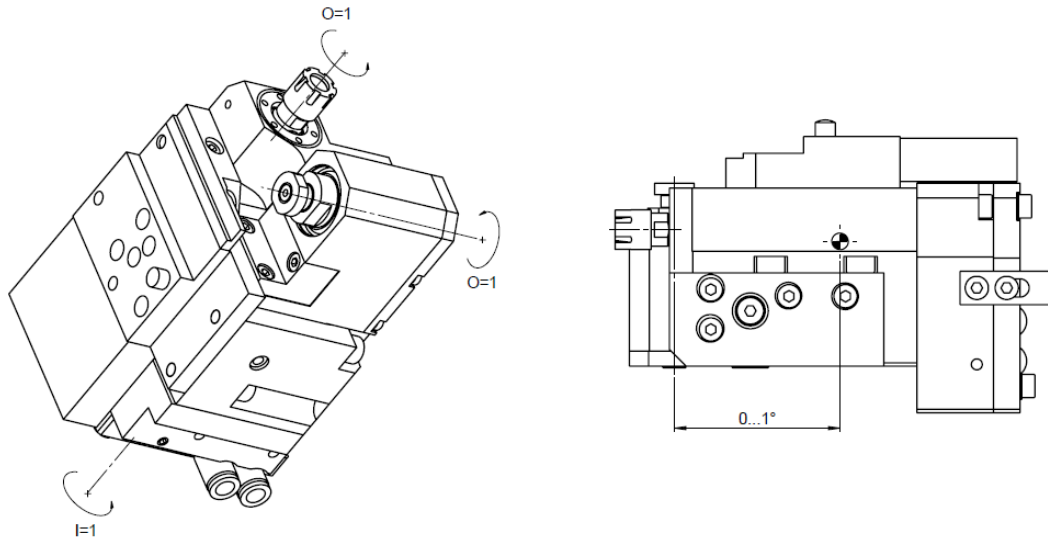
- The shaft Ø8 mm can be sloped until 1°.
- To be used with motor und protections of U30B.

**KSS663-II**

Maschine: CITIZEN  
Typ: R504  
Position, N°: Front gang tool post  
Arbeit über: Hauptspindel  
Arbeitstyp:    
i (n<sub>i</sub> / n<sub>o</sub>): 1 / 1  
Befestigung: ER11 / Welle Ø 8 mm

Werkzeughalter ölgekühlt.

**Infos:**

- Feinverstellung bis 1° auf dem Achse Ø8 mm.
- Mit Motor und Schutzhaube von U30B verwandt.