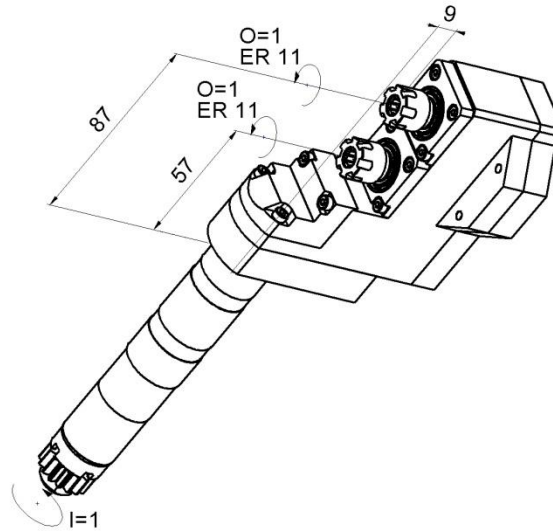

GSE-507-DS

Machine: CITIZEN Cincom

Type: L20E

Emplacement, N°: Coulisse

Travail sur: Broche principale

Type de travail:  n_{\max} : 8'000 [rpm] i (n_i / n_o): 1 / 1

Attachement: ER 11

Sans refroidissement

Infos:

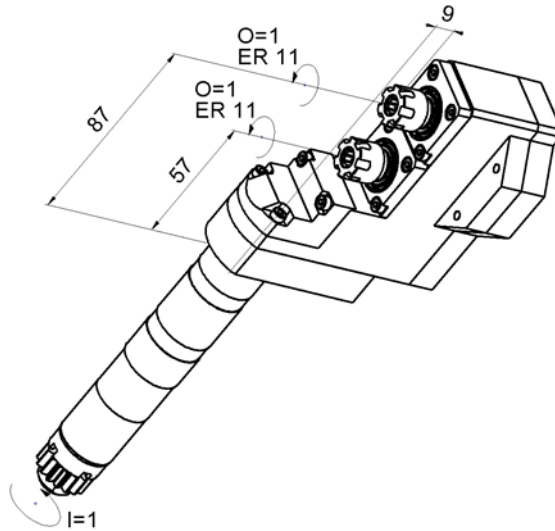
GSE-507-DS

Machine: CITIZEN Cincom

Type: L20E

Location, N°: Gangtool

Work on: Main spindle

Type of work:  n_{max} : 8'000 [rpm] $i (n_i / n_o)$: 1 / 1

Attachement: ER 11

Without coolant

Infos:

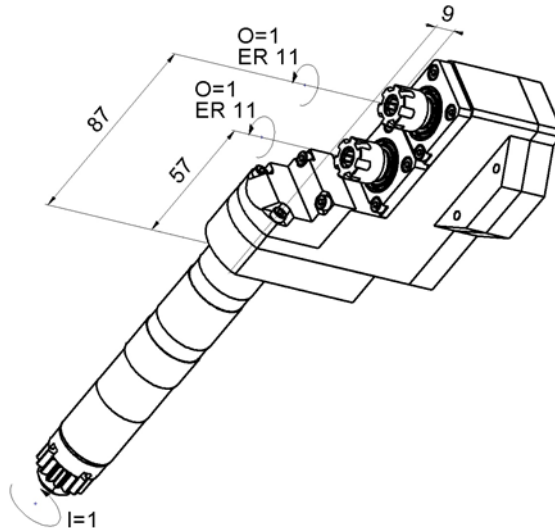
GSE-507-DS

Machine: CITIZEN Cincom

Typ: L20E

Position, N°: Vertikalhalter

Arbeit über: Hauptspindel

Arbeitstyp:  n_{max} : 8'000 [rpm] i (n_i / n_o): 1 / 1

Befestigung: ER 11

Ohne Kühlmittel

Infos:

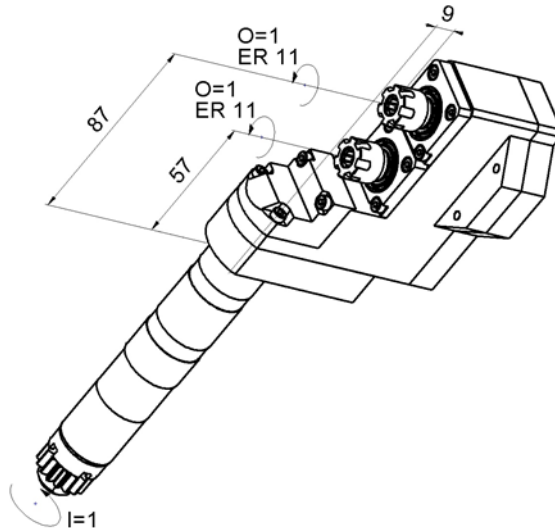
GSE-507-DS

Macchina: CITIZEN Cincom
Tipo: L20E
Posizione, N°: Slitta lineare
Lavoro al: Mandrino principale
Tipo di lavoro: 
 n_{max} : 8'000 [rpm]
 $i (n_i / n_o)$: 1 / 1
Ataccamento: ER 11
Senza refrigerante
Informazioni: